

eTow

USER'S GUIDE

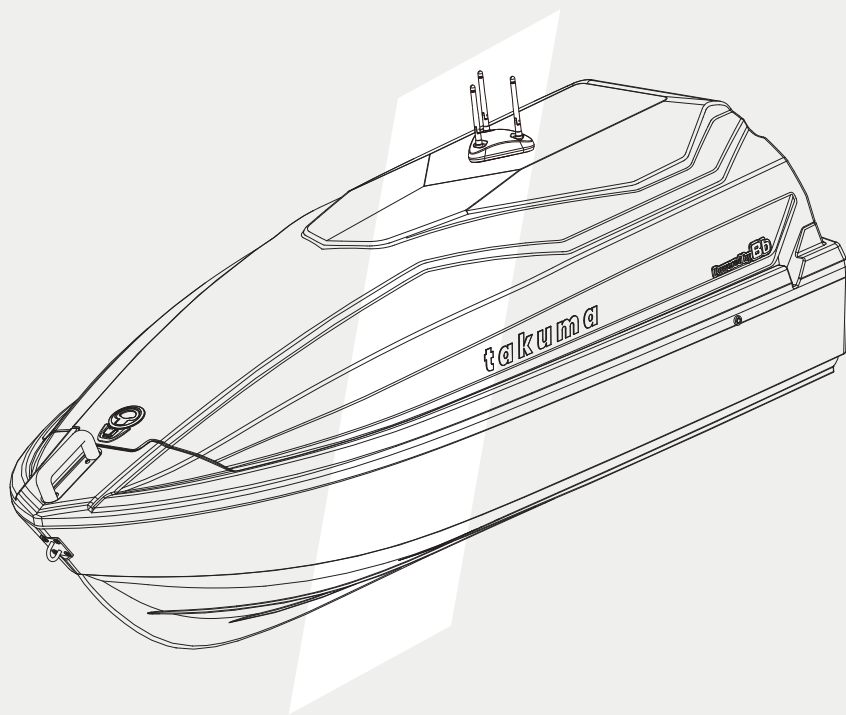

takuma

takes you further

Contents



- 1. GENERAL** 2
 - 1.1 About 2
 - 1.2 Safety 3
 - 1.3 Battery and components disposal 10

- 2. OVERVIEW** 11

- 3. PACKAGE CONTENTS** 12

- 4. PREPARATION** 14
 - 4.1 Battery connector ring installation 14
 - 4.2 Battery charging 14
 - 4.3 Remote charging 17

- 5. ASSEMBLY** 18
 - 5.1 Trolley assembly 18
 - 5.2 Loading 21
 - 5.2 Antenna installation 22
 - 5.3 Tow rope installation 22
 - 5.4 Hull drainage 23
 - 5.5 Battery installation 23

- 6. USE** 30
 - 6.1 Activation and pairing 30
 - 6.2 Connect ESC to TBS (coaching remote) 33
 - 6.3 Pairing failure 34
 - 6.4 How to use remote 35
 - 6.5 Safely cut-off 38
 - 6.6 Low battery warning 39
 - 6.7 Power off 40

- 6. AFTER USE** 42

- 7. MAINTENANCE & WARRANTY** 45

1.1 About

**Read the guide carefully.**

Please carefully read the instructions and the safety warnings presented in this guide before assembling and using the product. Keep the guide in a safe place in order to refer to it later.

Copyright © 2022 by TAKUMA.

The information presented in this guide is the property of TAKUMA. It cannot be reproduced, partially or in full, without prior authorization from us.

The illustrations are provided to facilitate comprehension. They have no contractual nature.

The information in this manual was accurate at the date of publication. However, specifications can be modified at any time without notice.

For up-to-date product information, please visit www.takuma.com

Symbols used

**Information:**

Indicates pertinent information making it easier to use the product.

**Warning:**

Indicates a potential risk that can cause slight injury or material damage if the instructions are not complied with.

**Danger:**

Indicates immediate danger that can cause serious and even fatal injuries and serious damage, if the instructions are not complied with.

1.2 Safety



To use the TAKUMA eTow safely and responsibly, the following instructions must be read and complied with.

TAKUMA cannot be held liable for non-compliance with the warnings and instructions in this guide.

1.2.1 Navigation

**Danger:**

Whenever you release the tow rope always release the trigger on the remote to stop the eTow.



Do not use in shore break.



Do not activate in water lower than 1 meter/ 3 feet.

The TAKUMA eTow is subject to local laws and regulations in terms of navigation. It may be necessary to obtain a license or a permit to use TAKUMA eTow in certain areas or countries. Always observe local rules and regulations when using this product.

Never navigate alone.

Give priority to the right (starboard) at sea, on lakes and rivers.

At sea, when leaving the coast, move at a slow speed (less than 5 knots or 9 km/h), without flying, until you leave the coastal strip of 300 metres.

In ports, comply with the maximum speed (5 knots except for other local regulations). Do not fly.

In rivers and lakes, obtain information on the authorized navigation zones and speeds.

Observe the body of water where you will be moving about before getting into the water.

Make sure there is no dominant wind that will push you out to sea.

Be able to keep track of where you are at any time in your navigation zone. Where did I leave from, are there any swimmers and where are they? Are there any other watercraft, where are they, how fast are they moving?

The TAKUMA eTow must never be used near other people (swimmers, surfers, divers, etc.). Also always maintain a safe distance of 100m with respect to other watercraft or any other obstacle.

Do not navigate in waves, as your view of swimmers and/or surfers will be obstructed.

Do not use TAKUMA eTow in shallow water (less than 1 meter / 3 feet deep), near rocky areas or in the presence of algae, or in the open sea.

Never use TAKUMA eTow in sea or weather conditions that are above your level of physical ability.

Do not use the TAKUMA eTow in a thunderstorm or severe weather conditions.

Never use your TAKUMA eTow near shore break waves. Doing so may cause serious damage. Avoid all contact between the eTow and rocks, coral, sticks or other types of debris.

In the event of a problem during navigation (operation ceases), lie flat on your stomach on your board and paddle in the direction of the coast or the nearest shelter.

Do not use for jumps and stunts as it make cause damage to the eTow.

Use in wavy conditions at your own risk. Takuma will not assume responsibilities for damages in these conditions.

1.2.2 Users



Using TAKUMA eTow can be dangerous:

This product must be operated with caution and common sense. It requires some foiling ability.

When using this product, you are responsible for your safety as well as the risks. Always take the safety of your environment into consideration.

The TAKUMA eTow is an individual product and should only be used by one adult at a time.

The TAKUMA eTow is not to be used by children under 18 years of age.

Make sure you are able to use this product in a safe and responsible manner before you start using it. Do not use it if you are not in good physical health, if you are not an experienced swimmer, or if you are under the influence of alcohol, drugs or medications.

Maintain a safe distance from others and away from any obstacles. Check for any legal requirements and rules that may apply in your location. Observe local weather forecasts and never go out in dangerous conditions.

The following are required when using your eTow:

- **a certified personal flotation device (PFD)**
- **a certified helmet**
- **a full neoprene wetsuit, booties and gloves**
- **a lighted positioning device (a waterproof torch as part of the PFD or worn by the user)**
- **a VHF radio or a waterproof mobile telephone**

By using this product, you agree that you do so at your own risk. TAKUMA does not accept any responsibility for personal injury or material damage in the case of an accident due to incorrect use.

1.2.3 eTow



Do not leave your TAKUMA eTow in direct sunlight or moving in the wind for long periods of time when not in use.

Do not leave your TAKUMA eTow on hot surfaces such as asphalt or sand for long periods of time.

Never leave your TAKUMA eTow in an overheated place, such as in a hot car. Doing so may cause serious damage.

Do not operate your TAKUMA eTow when it is not in the water. Doing so will cause it to overheat and may permanently damage the motor.

1.2.4 Impeller



Risk of personal injury:

The TAKUMA eTow impeller carries risks of serious and even fatal injuries.

Keep body, fingers and toes away from the TAKUMA eTow's spinning impeller.

Never start the impeller when out of the water.

Never remove the casing of the impeller when connected to a battery.

Never touch or handle the impeller while the battery is connected. If intervention is required on the impeller (to remove a foreign body, for example), the battery must be removed first.

1.2.5 Electrical parts, batteries and chargers



Before handling the electrical connections of the TAKUMA eTow, the battery or the chargers, make sure you are in a dry place away from water splashes. Never operate in the water or in the presence of humidity.

Never open the electrical connectors when your eTow is on the water.

Never change your battery when your eTow is on the water.

Do not attempt to open or modify the electrical parts, battery or charger.



Do not use or charge a damaged battery, if it was involved in any kind of heavy impact or crash. Doing so can cause the battery to catch fire.

Please contact your local TAKUMA dealer for further assistance.

Signs of a damaged battery:

Loose screws/rivets/connectors

Split or deformed case

Acidic smell

Unusually hot temperature during charging (80°C or more)

Do not disassemble the battery in any way. Water may penetrate causing battery to catch fire or explode.

Do not use other batteries or chargers than those sold by TAKUMA. Any damage caused by the use of another battery or charger will not be covered by warranty.

Place the battery and the charger in a clean and dry place, out of the reach of children under 18 years old.

Keep the battery away from fire, heating sources and out of direct sunlight.

The battery must be used in the temperature range from 0°C to 40°C (32°F to 104°F). Do not use or charge the battery at high temperature. Use of the battery in environments above 40°C/104°F can lead to a fire or an explosion.

Use of the battery below 0°C/32°F can lead to permanent damage to the battery.

Avoid any form of impact or physical damage.

Always inspect before every use.

Do not use if there's visible damage or cracks on the housing, loose screws, acidic smell. Doing so can lead to fire.

Do not let the connectors come in contact with water or wet hands.

Make sure there is no corrosion in the battery before connecting to your eTow or charger.

After use, make sure battery cap is completely dry before putting it back on.

Only use the charger supplied to charge the battery.

The battery charger must be used in a standard voltage outlet (110V or 220/230V).

Always charge your battery in a dry place.

If the battery has been exposed to water, place it in a cool dry place until it is totally dry.

If a charger is wet, stop using it immediately.

Never leave unattended while charging.

Do not leave the charger plugged in when not used.

If the battery is not to be used for a long time, then it needs to be charged every 3 months to 80% in order to preserve its lifespan.

1.2.6 Electronic Speed Control (ESC)



The ESC is mounted inside the TAKUMA eTow.
It allows you to vary the jet's speed via the remote control.
It is controlled by the remote control.

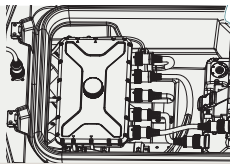

Connectors:

Never allow sand and/or water to get in the connectors of the ESC or battery, or it may cause significant damage.



Only use the ESC for the propulsion. Using the regular non ESC from Takuma will cause irreversible damage to the propulsion.

Do not use other ESC than the ESC sold by TAKUMA. Any damage caused by the use of another ESC will not be covered by warranty.

If the product is not to be used for an extended period, the ESC must be stored

so as to remain clean and dry.

Keep the ESC away from sources of heat and out of direct sunlight. Avoid any high temperatures.

Do not leave or use the ESC near fire.

Do not alter or disassemble the ESC.

Prevent any impact with the ESC and do not drop it.

If your ESC is damaged, contact your TAKUMA authorized dealer for further assistance.

1.2.7 Remote control

Do not open the remote control case.

Do not modify or disassemble the device. If the device becomes damaged, stop using it immediately.

Do not expose this device to extreme temperature.

Never use the device near medical devices and/or near a person with an electronic medical device (such as pacemaker, etc.).

Do not use the device in an airplane.

2. OVERVIEW

1.3 Battery and components disposal

When it is suspected that the device is no longer safe, for example after damage incurred during transport or use, the defective device must be taken out of service. It is necessary to ensure that it will not be used later. Please contact your local TAKUMA dealer for more information.

The defective product will be entrusted to authorized technicians for the purposes of control.



This marking indicates, in the European Union, electric and electronic devices that must be separated from household waste. In order to preserve the environment, this device must be disposed of in compliance with the appropriate sectors according to the national regulations of each Member State.

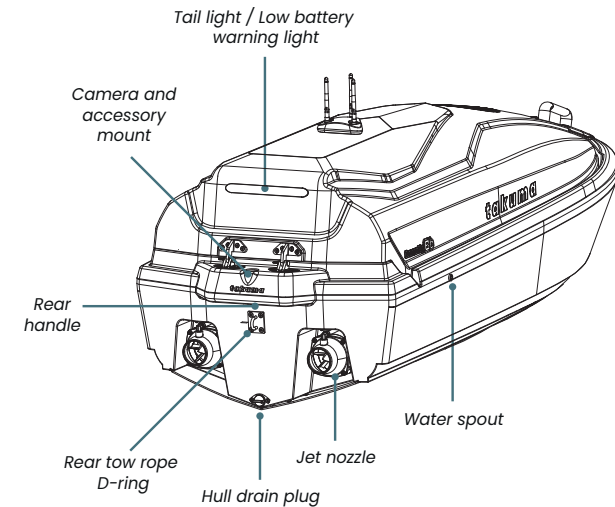
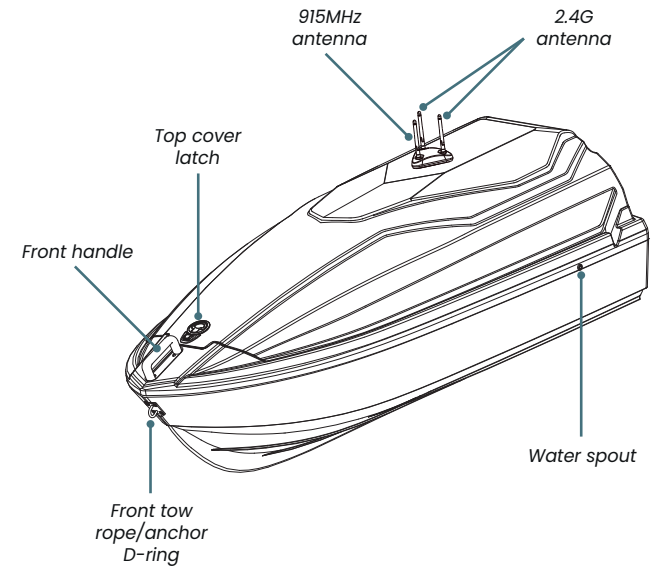
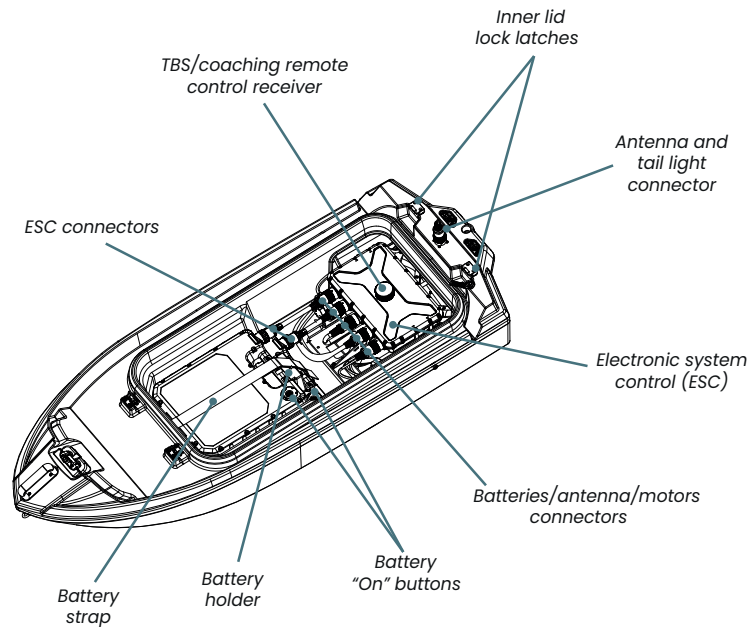

3. PACKAGE CONTENTS

Box 1:

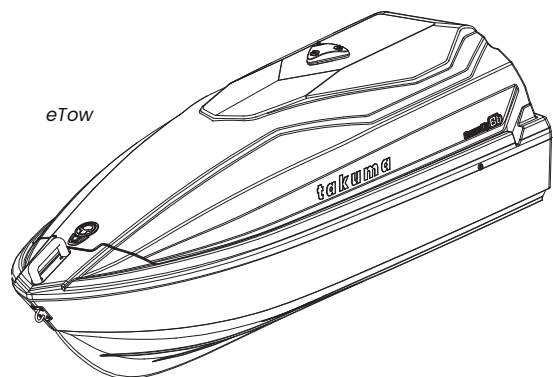

Tow rope and carabiner

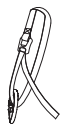

Trolley strap and carabiner

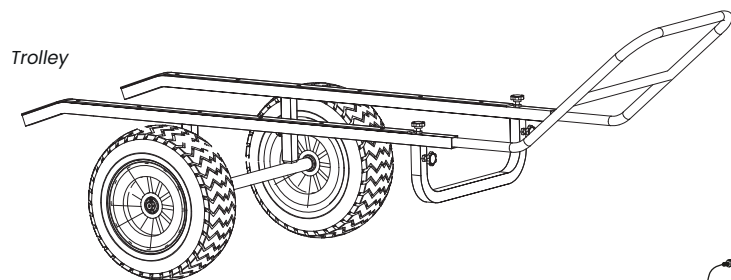

Antenna X 6
(4 x 2.4G)
(2 x 915MHz)



Battery holder



Battery connector ring and cap x 2

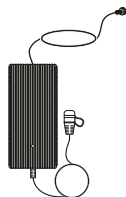

Battery charger x 2



Remote control charger & USB cable



Remote control

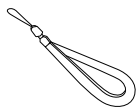

Wrist strap



Connector grease

Box 2:

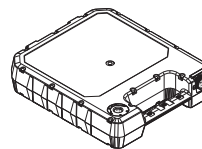

Battery

Box 3:

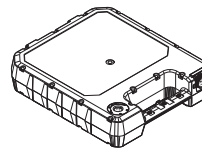

Battery

4. PREPARATION

4.1 Battery connector ring installation

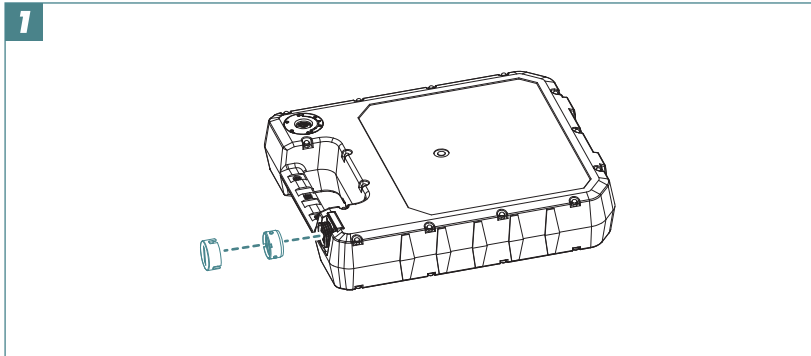

Make sure the connector ring is screwed on securely

4.2 Battery charging



Before using for the first time, charge the battery 100%.

Charge the battery at least once within 3 months after delivery.
The battery will reach its full capacity after 3 or 4 charging/
discharging cycles.



*Check that the device and the battery connector are completely dry.
Ensure that you are in a dry place away from splashes of water.
Never operate in the water or in the presence of humidity.*

*Do not charge immediately after use. Charging a hot or cold battery
can damage cells. Wait 30mins to 1hr to let the battery cool down or
warm up to room temperature.*

Best temperature for charging is between 15-25°C.

Do not drop battery.

Charging a damaged battery can cause the battery to catch fire.

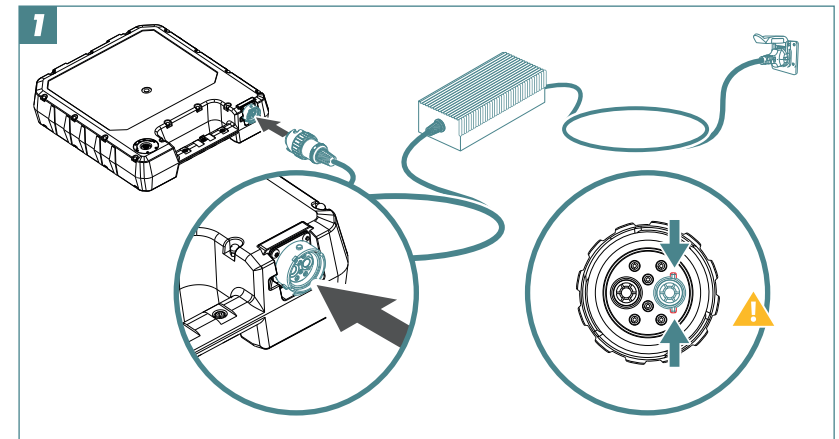

*The pins will only connect if the notches are properly aligned. No
great force is needed.*

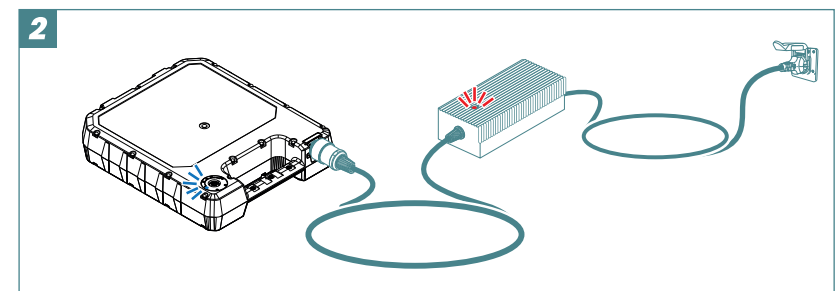

Once the battery is connected to the charger, the light on the charger should turn red.

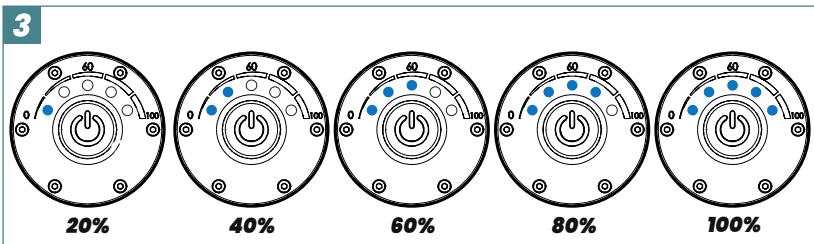

The blue battery LEDs allow you to monitor the progression of the charge.

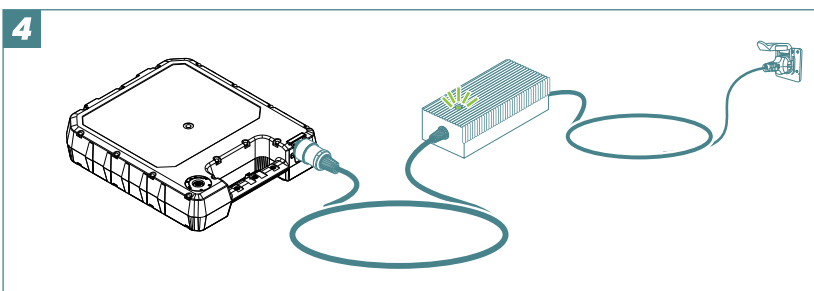

Once the battery is fully charged, all the LEDs go out and the charger indicator turns to green.

Disconnect the charger from the wall socket.

Disconnect the battery from the charger. Place the protections back on the connectors in order to ensure watertightness.

4.3 Remote charging



Before using for the first time, charge the remote control 100%.

Charge the remote control at least once within 3 months after delivery.



The remote control must be completely dry before charging.

Always make sure remote control is at an adequate battery level before each session.

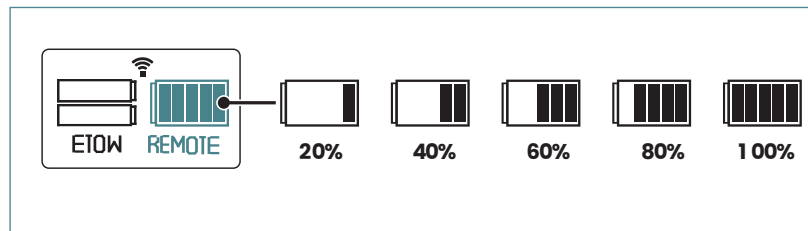
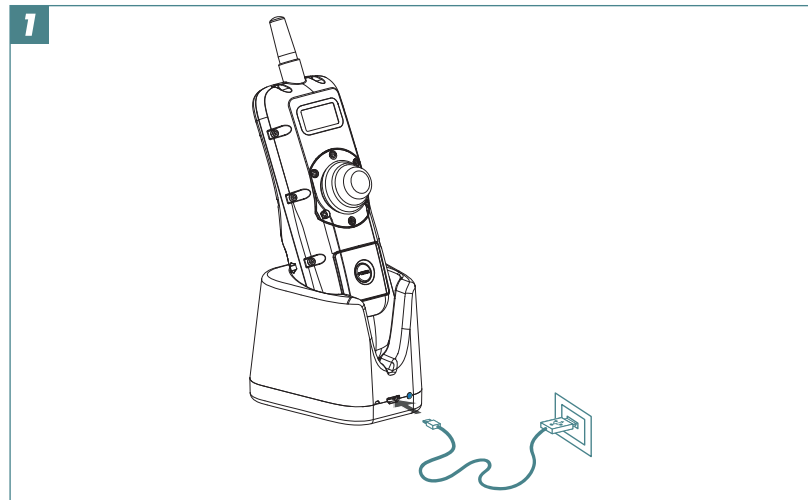

5. ASSEMBLY



To facilitate the assembly of the TAKUMA eTow, we recommend watching the tutorials on our channel <http://youtube.takuma.com>



Assemble your TAKUMA eTow in a clean and dry place.

5.1 Trolley assembly

1

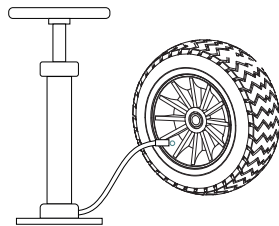

Lower tire pressure by approximate 50% of the maximum PSI for beach conditions.

2

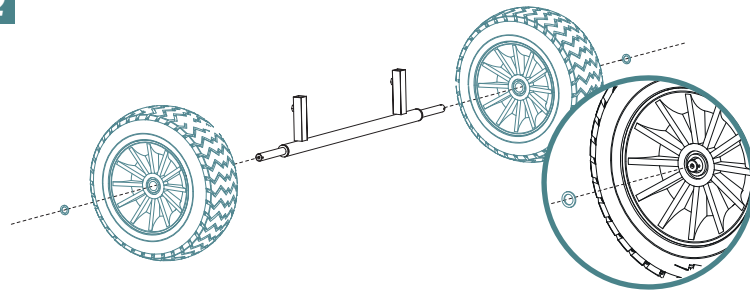

3

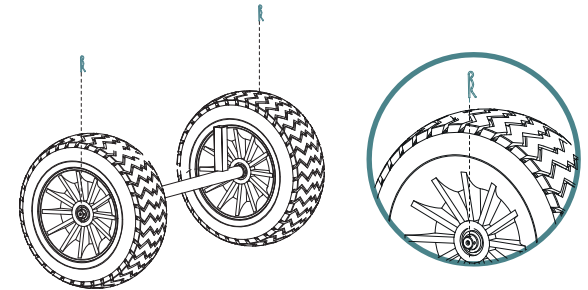

4

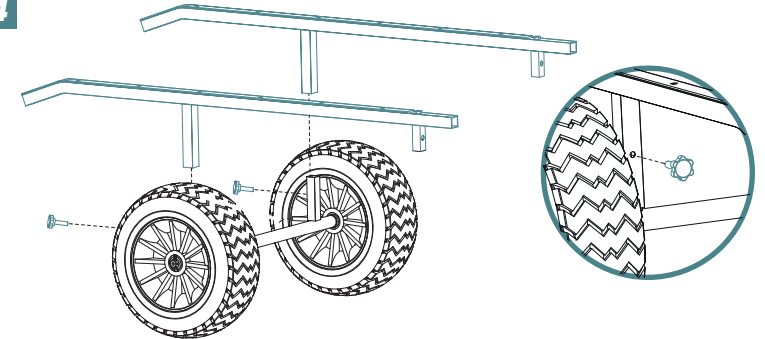

5

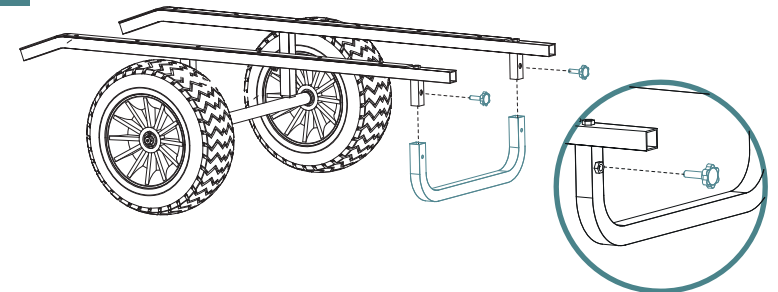

6

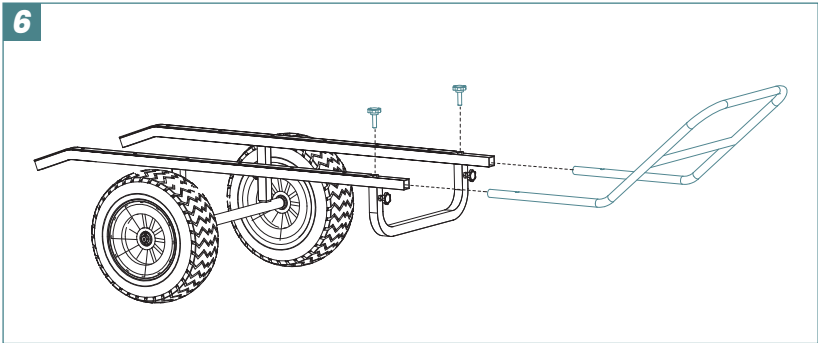

7

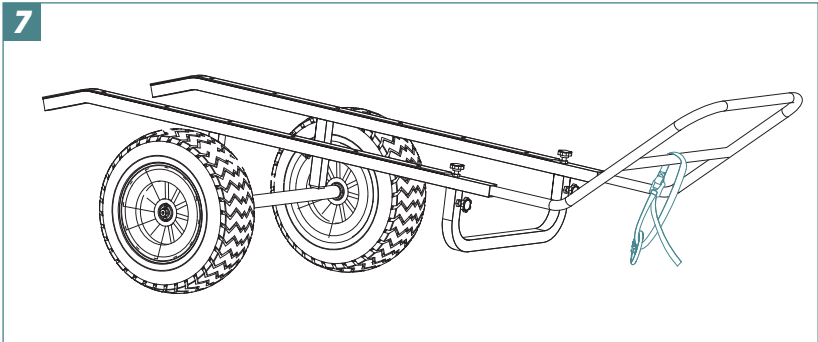

5.2 Loading

1

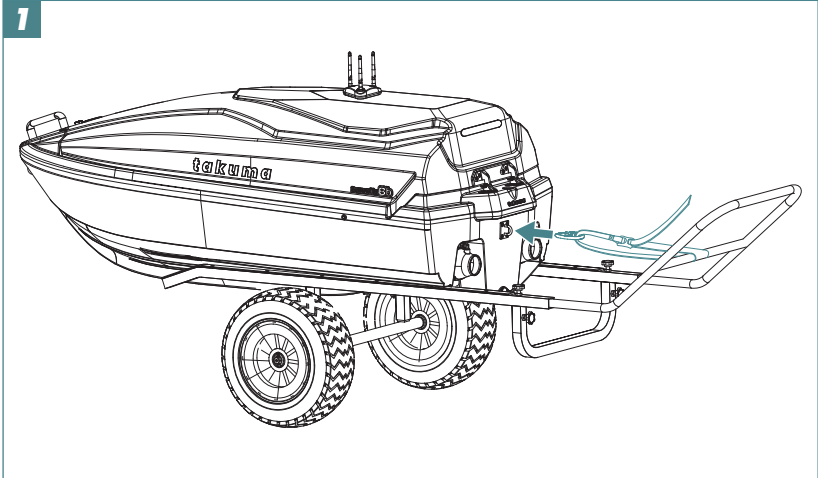

2

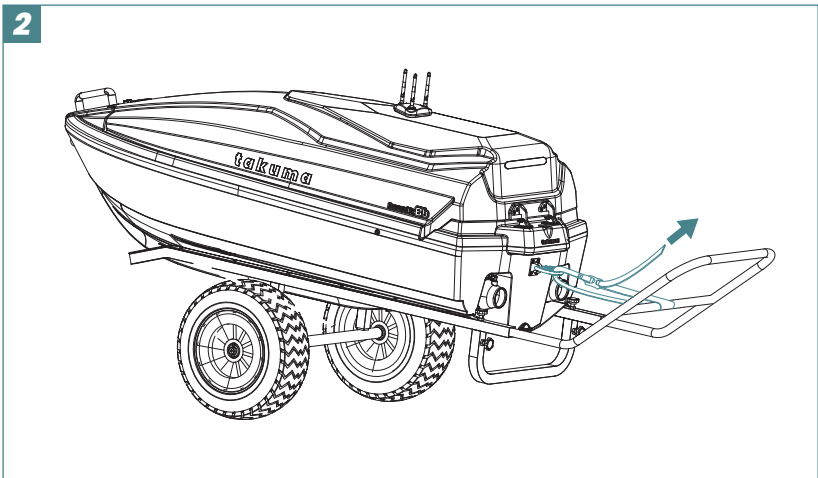

5.3 Antenna installation

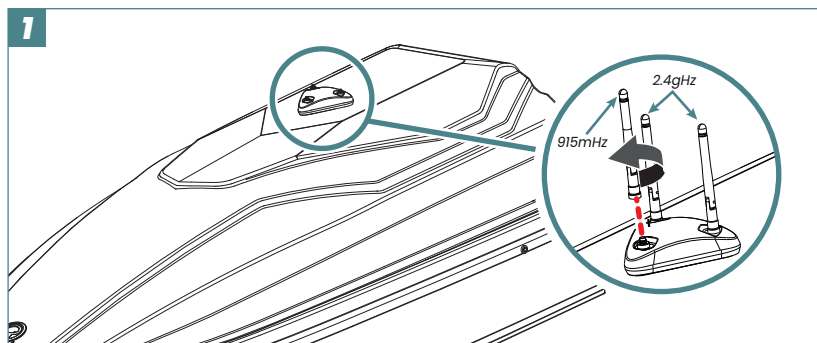

5.4 Tow rope installation



Rope length can be adjust as needed. Recommend shorter for waves and longer for free ride.



Tow rope must be at least 2cm in diameter or else it can get sucked in the jet intake causing irreversible damage.

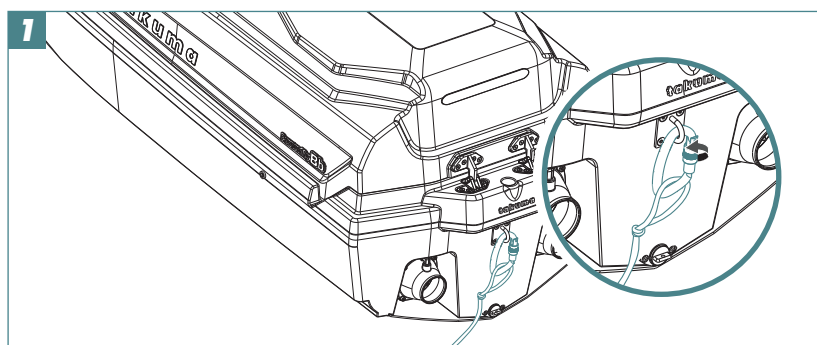

5.5 Hull drainage



Always make sure hull drain plug is closed before use.

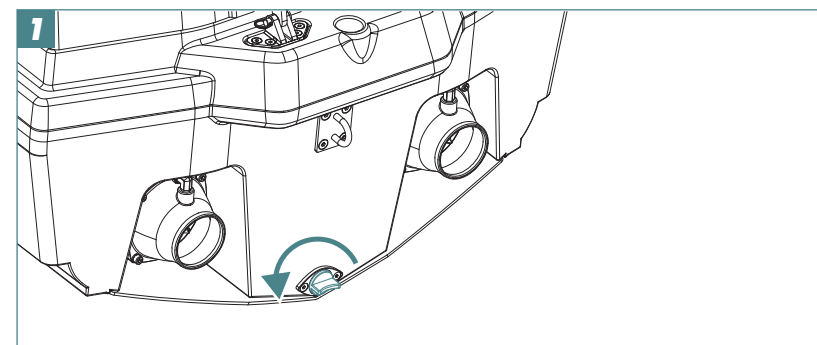

5.6 Battery installation



Only use 35A batteries and both fully charged for optimum performance

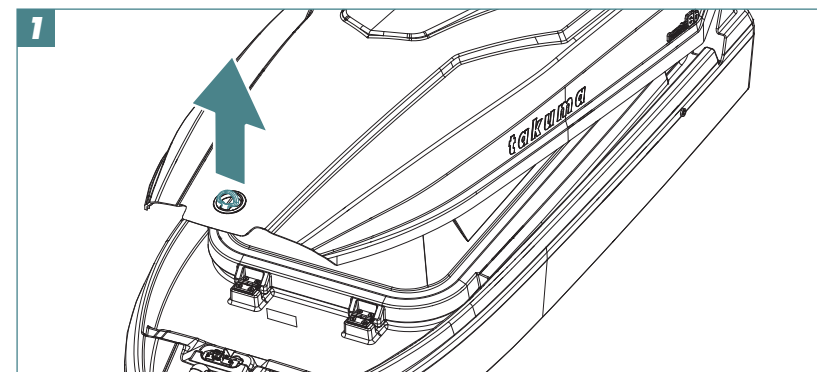

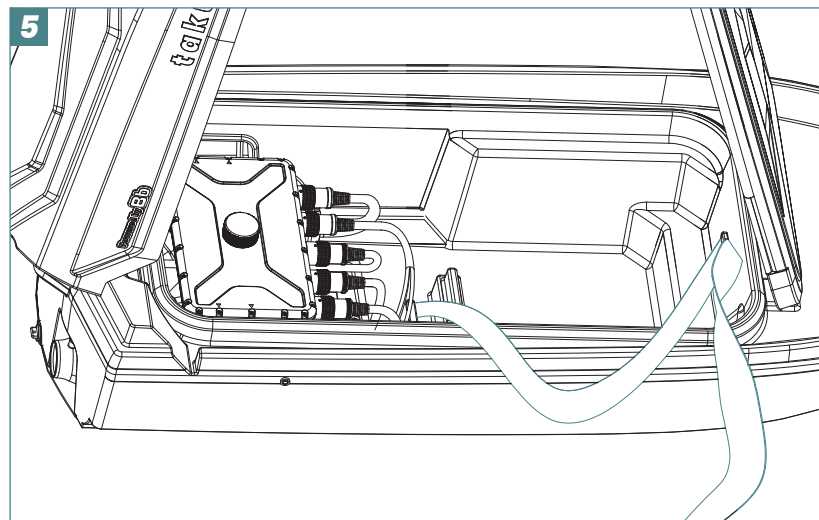
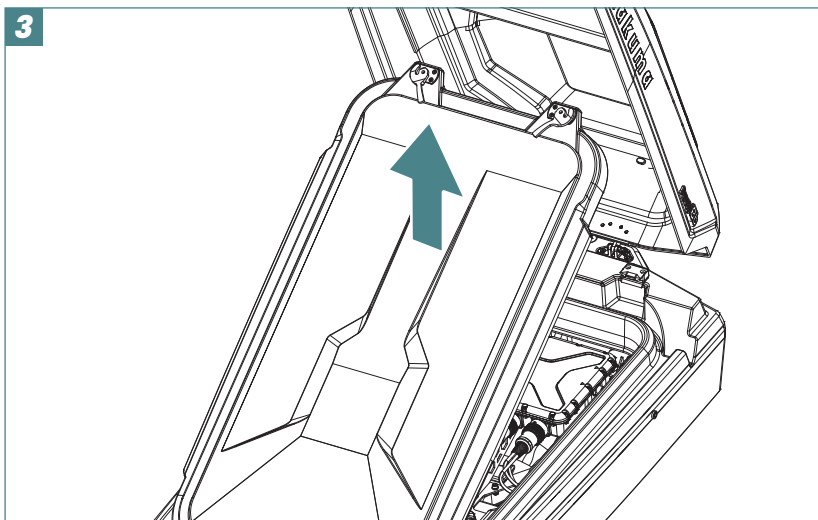
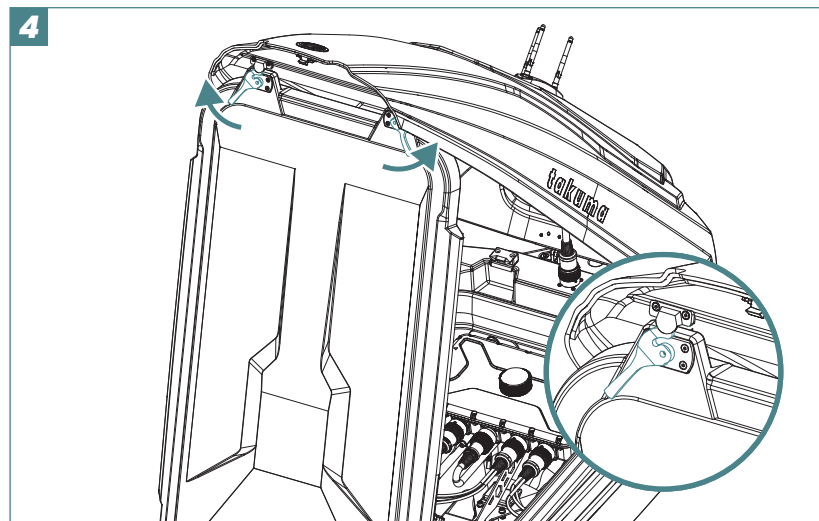
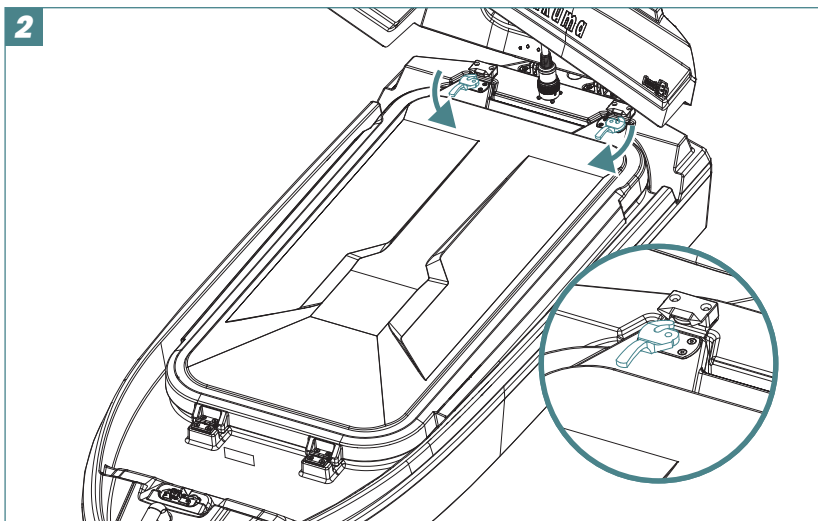

Move battery strap to the side when installing the batteries.

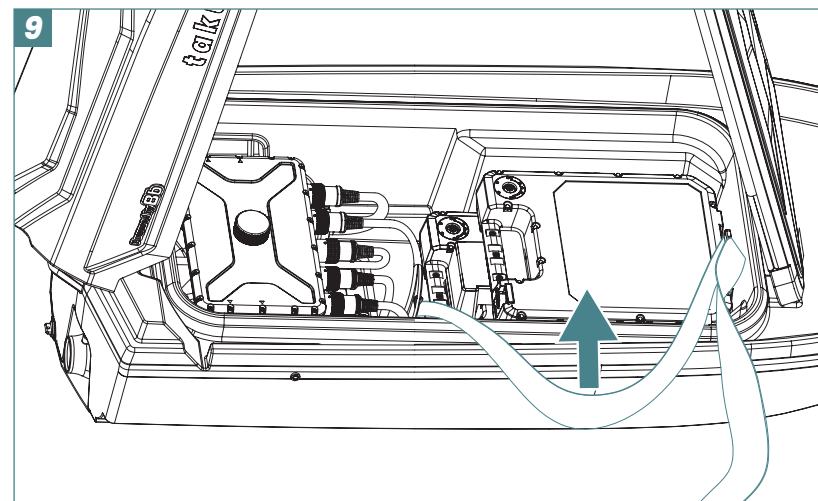
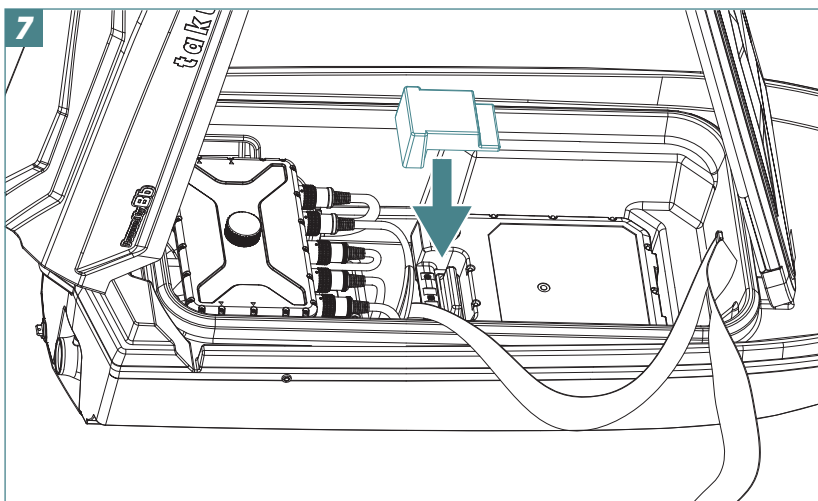
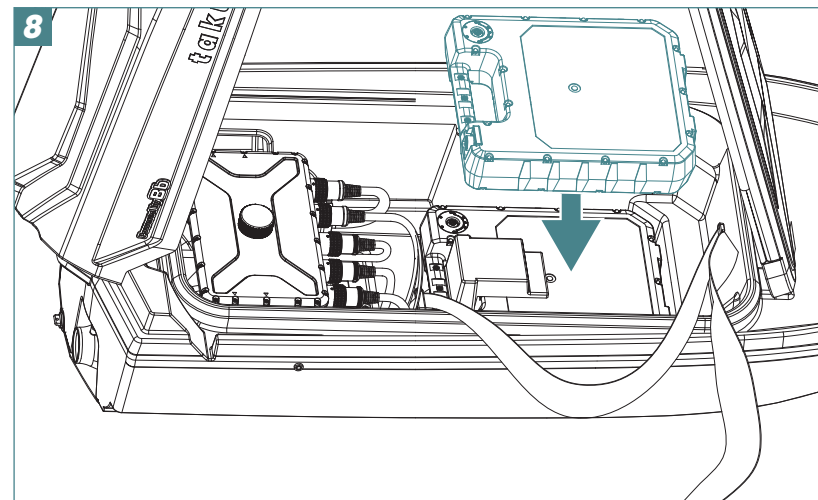
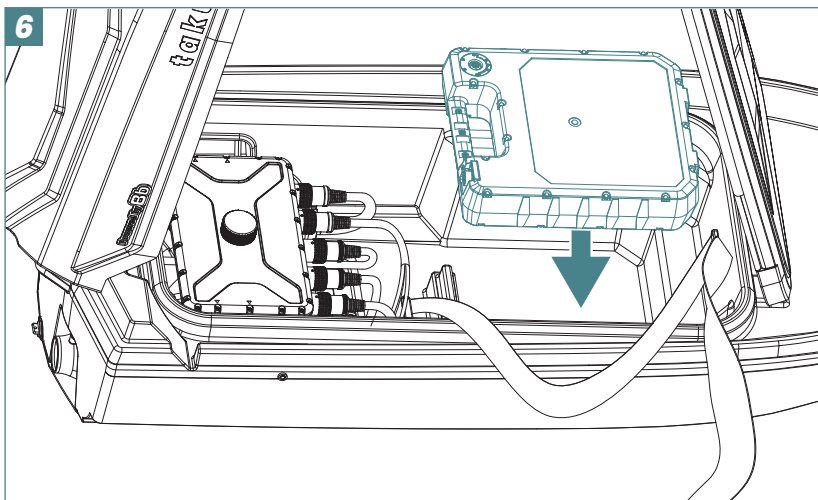

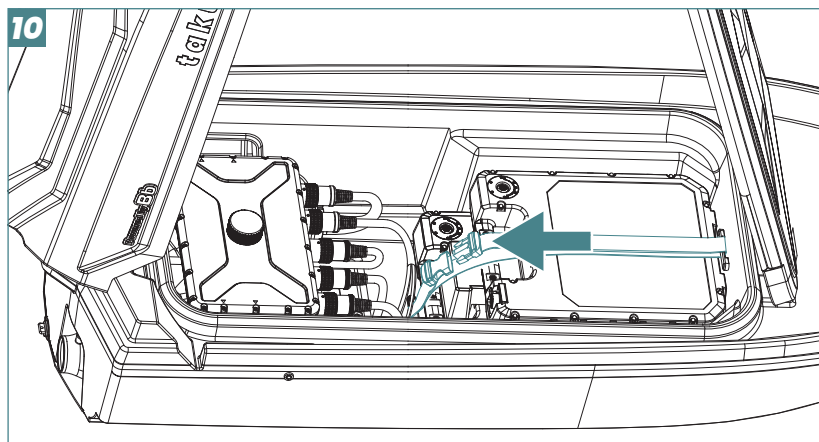

Strap must be locked and fastened to keep batteries in place.

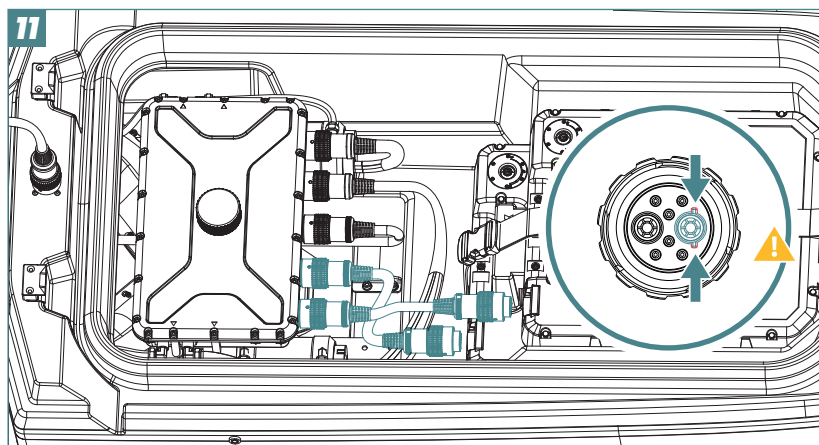

The pins will only connect if the notches are properly aligned. No great force is needed.

Always make sure connectors are securely fastened to prevent water entry.

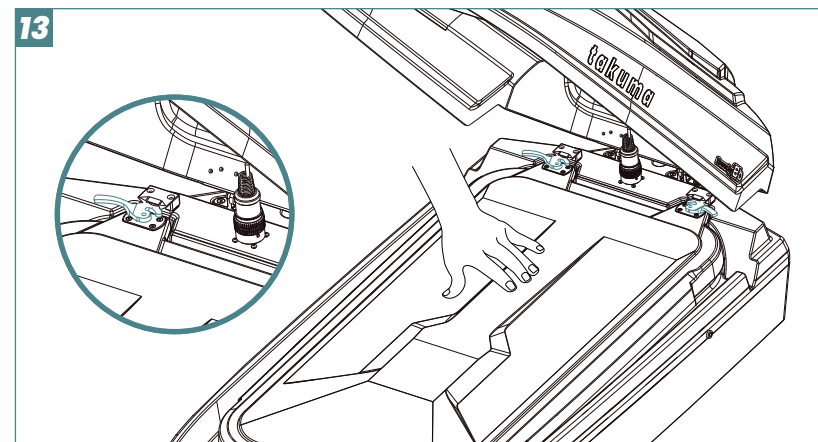
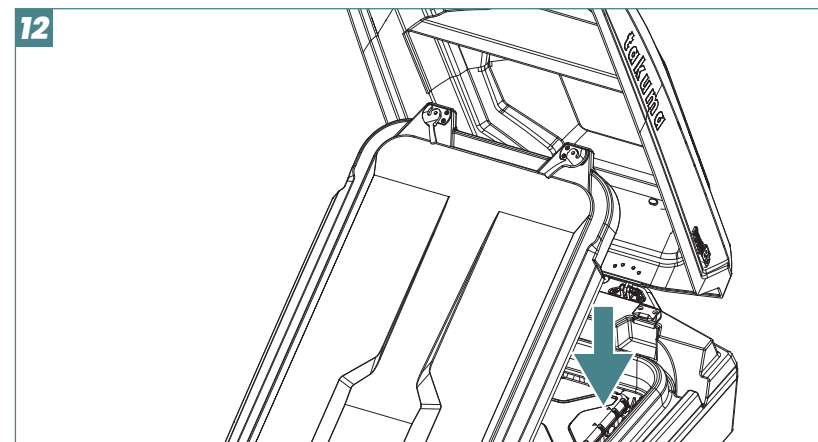

Press down on inner cover with some force to make sure the locks are secured underneath the hinges for a water tight seal.

6. USE

6.1 Activation and pairing

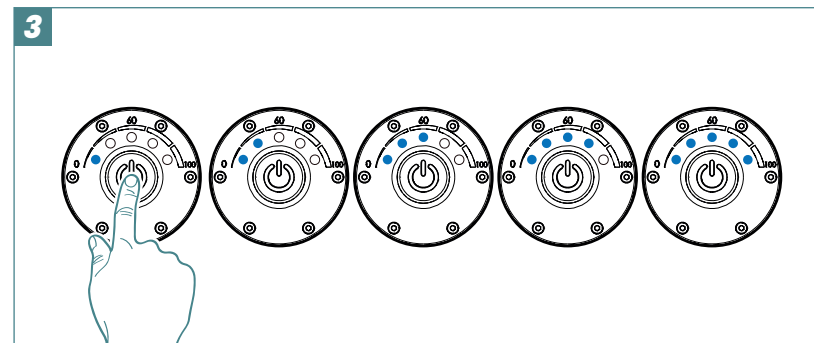
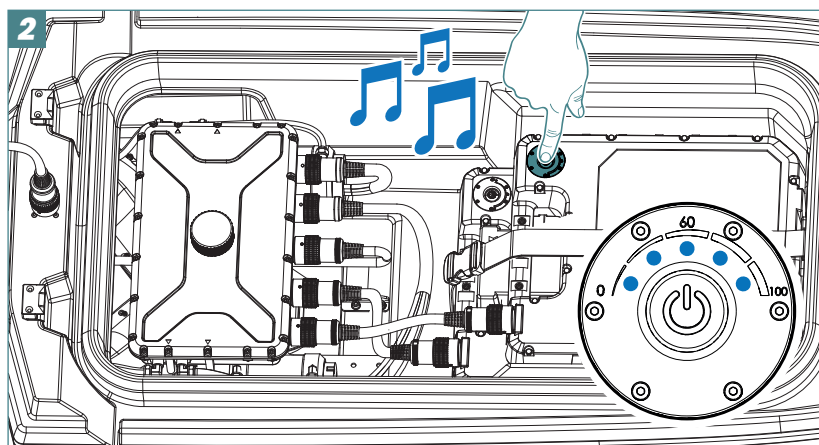
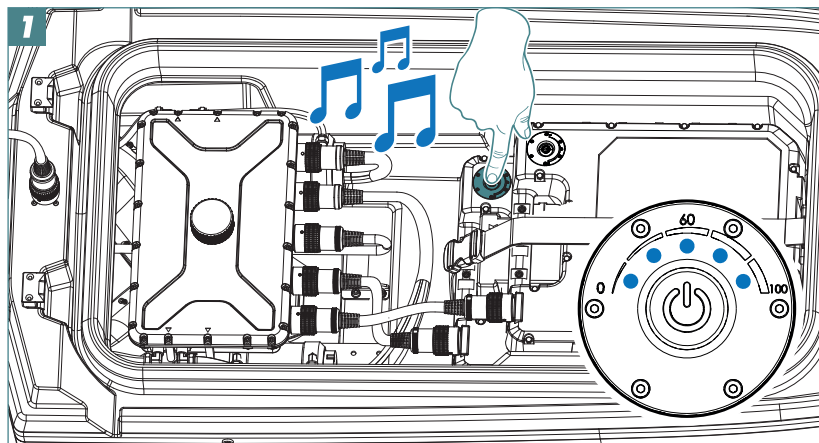

Keep you finger on the button until all 5 led lights are on.

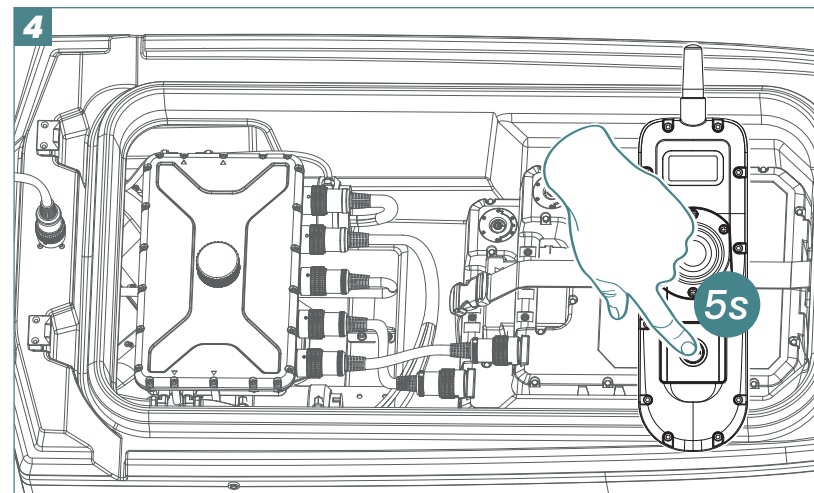

When pairing a new remote, keep your finger on the power button until it is paired. The pairing needs to be completed within the 1st minute of turning on the eTow or else you will need to restart the process.

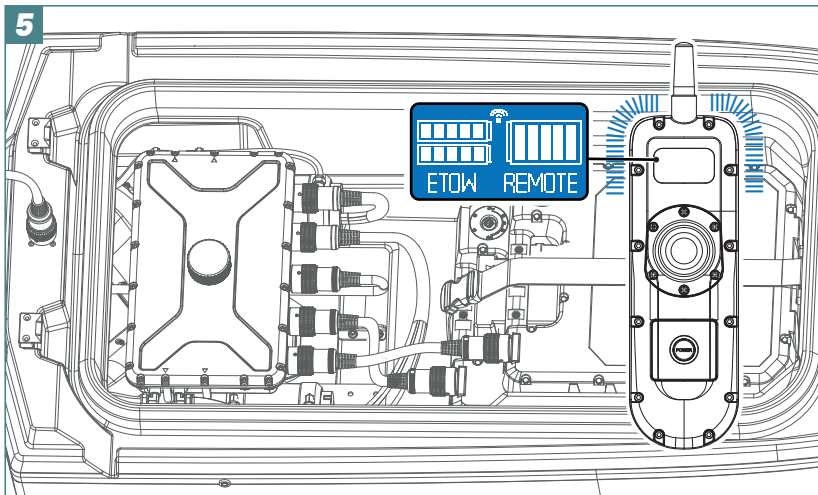

6.2 Connect ESC to TBS (coaching remote)

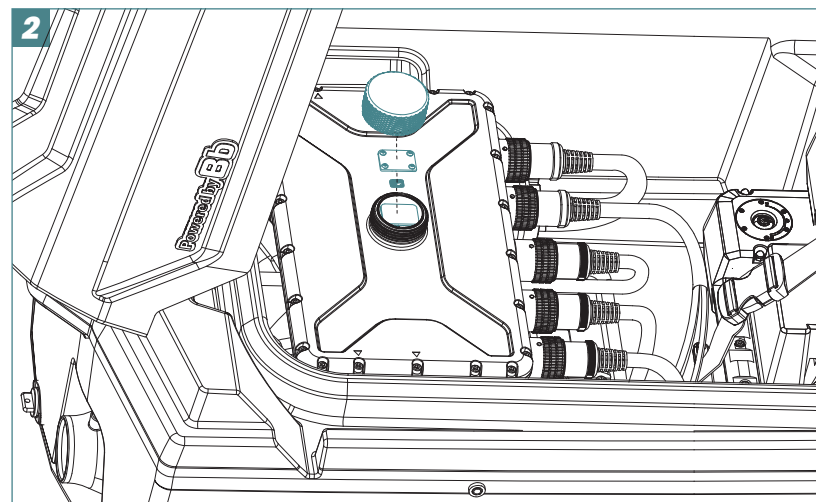
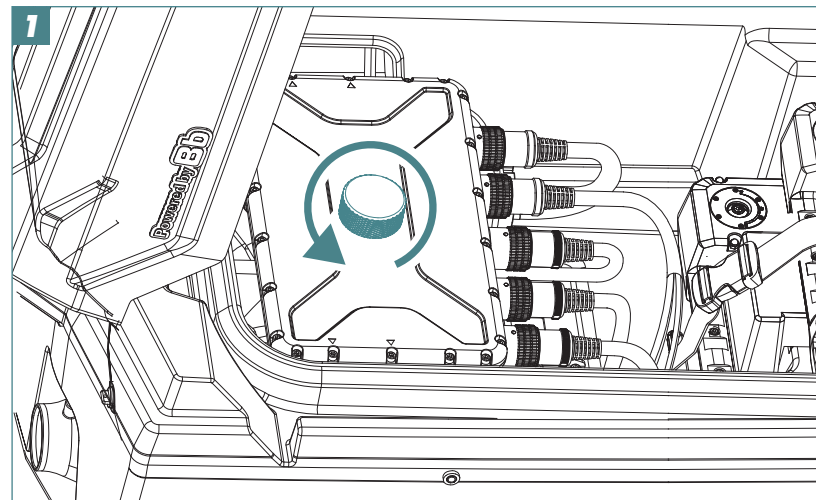

Always make sure the ESC cap is fastened securely for a water tight seal.

6.3 Pairing failure

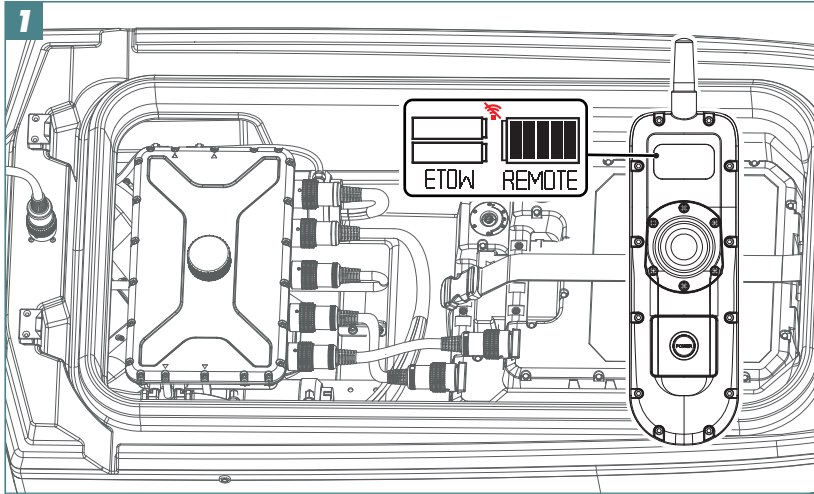

The barred wifi is shown in the middle of the screen.

Make sure that connectors are clean and completely dry with a thin layer of connector grease.

Try to pair again, turn off the remote and battery and repeat the activation and pairing steps.

6.4 How to use remote



To facilitate learning how to use the TAKUMA eTow, we recommend watching the tutorials on our channel <http://youtube.takuma.com>. We also recommend to start practicing with an instructor.



Raise remote for better reception in open swell or for coaching.



Whenever you release the tow rope always release the trigger on the remote to stop the eTow.

6.4.1 Remote control

1

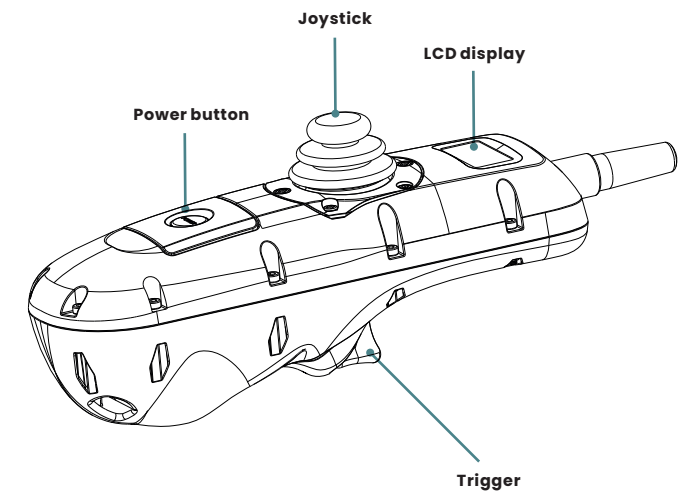

6.4.2 Trigger and joystick

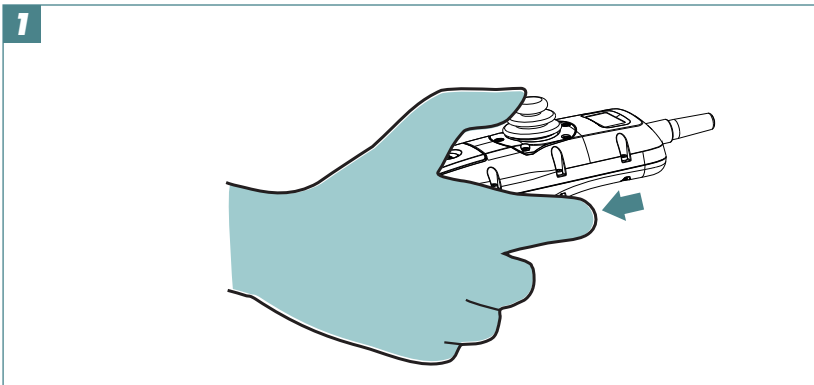

Press down on the trigger and click joystick forward to start the water jets.

The trigger must be pressed continuously during the entire use.

Once the trigger is released the propulsion stops.

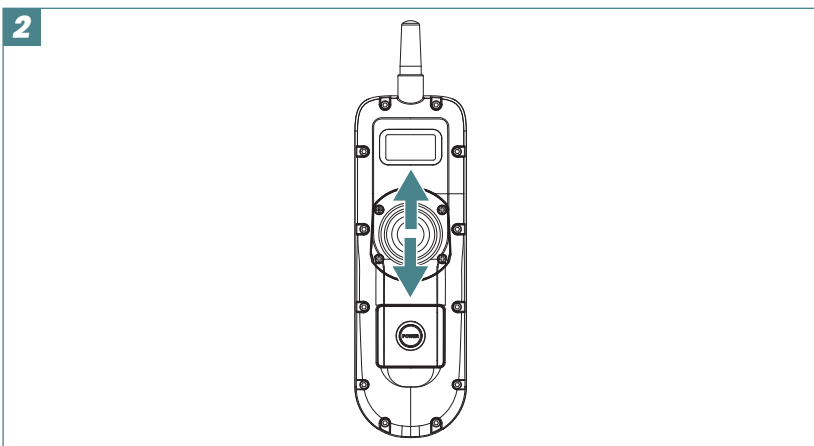

Click joystick up and down to adjust speed.

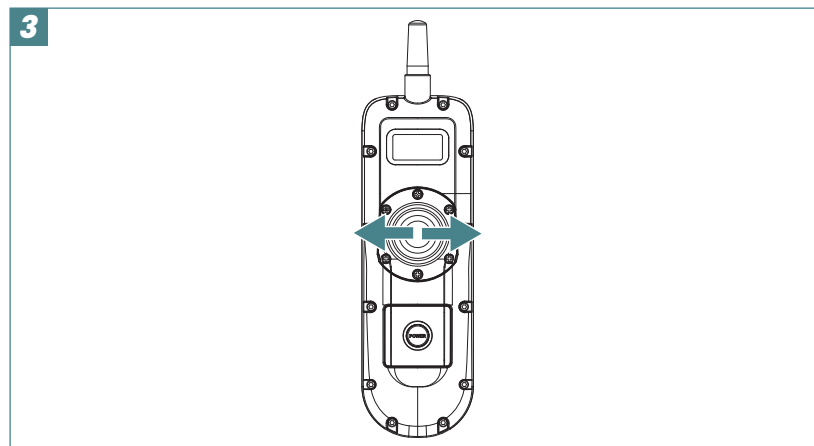

Press joystick left and right to assist with turning.

6.5 Safety cut-off

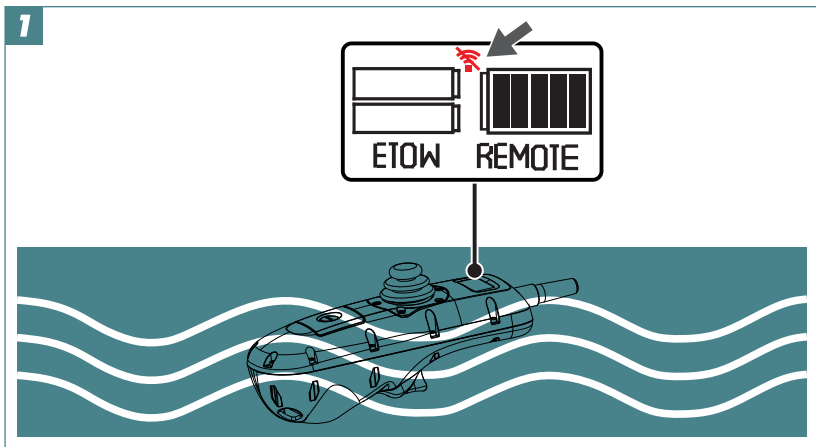

If the remote hits the water the connection and the motor will cut off.

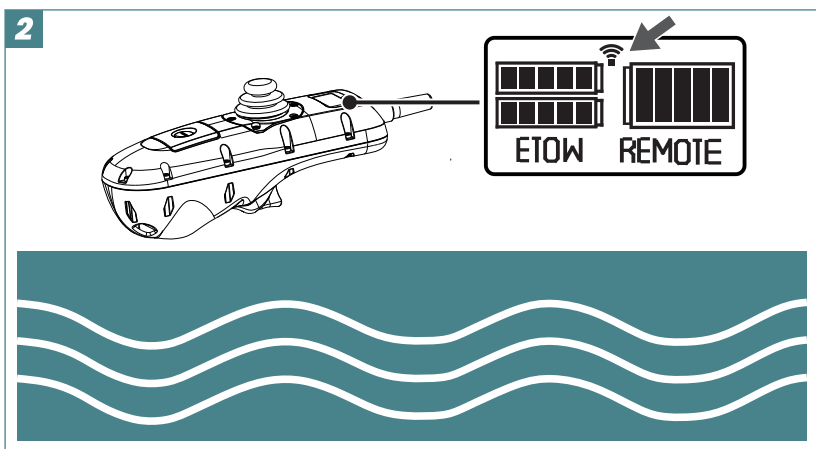

The signal automatically comes back on when the remote control is outside the water.

6.6 Low battery warning



Always check the battery levels regularly during use. When the tail light is flashing and the remote is showing "Battery Low", it's an indication to head closer to shore.

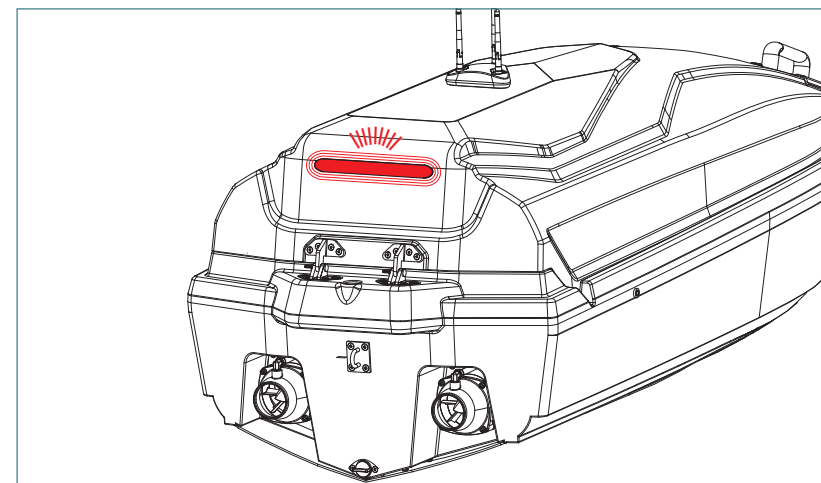
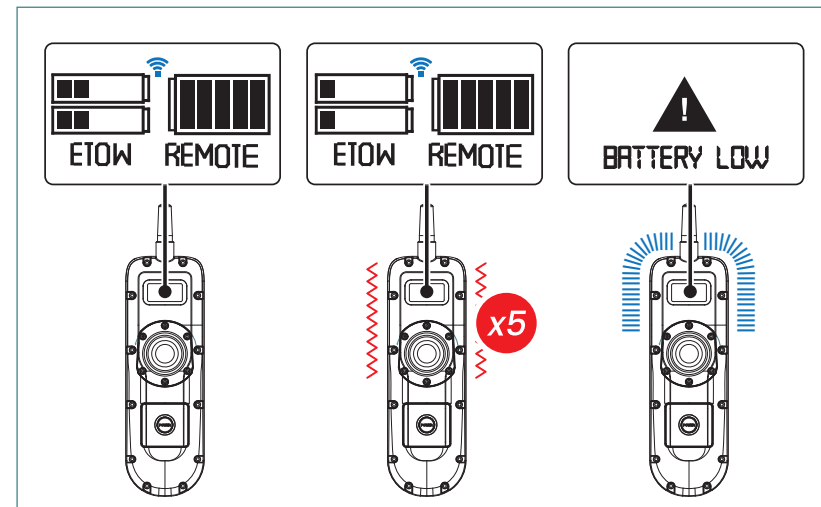

6.7 Power off

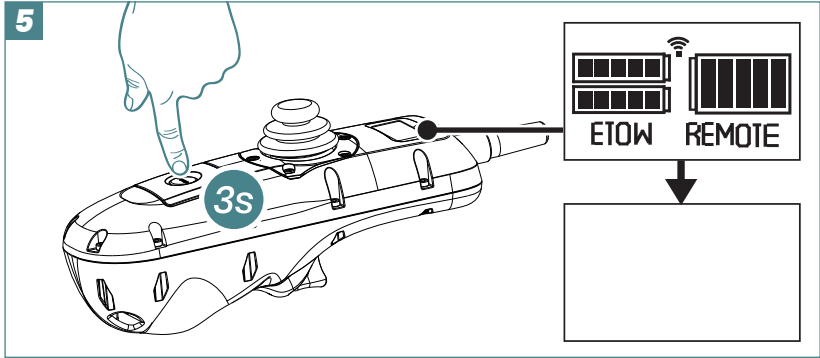
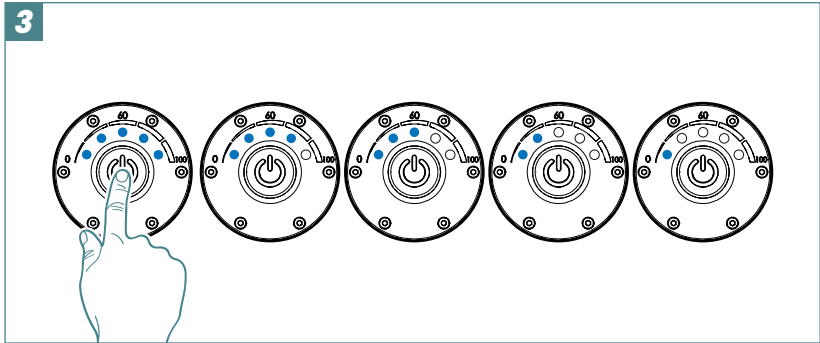
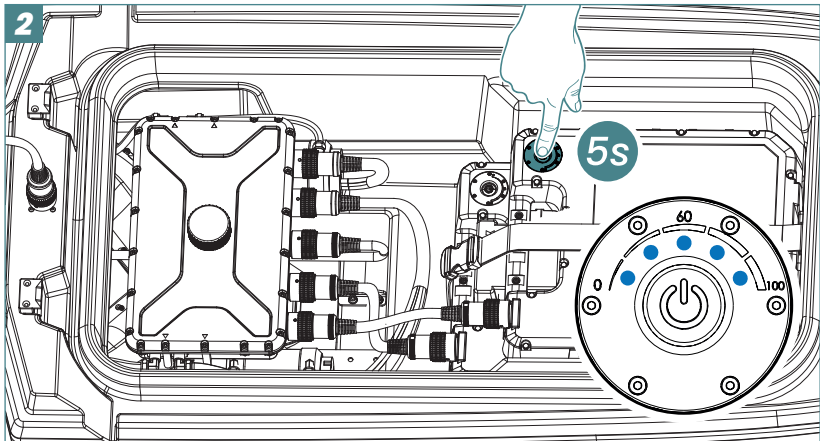
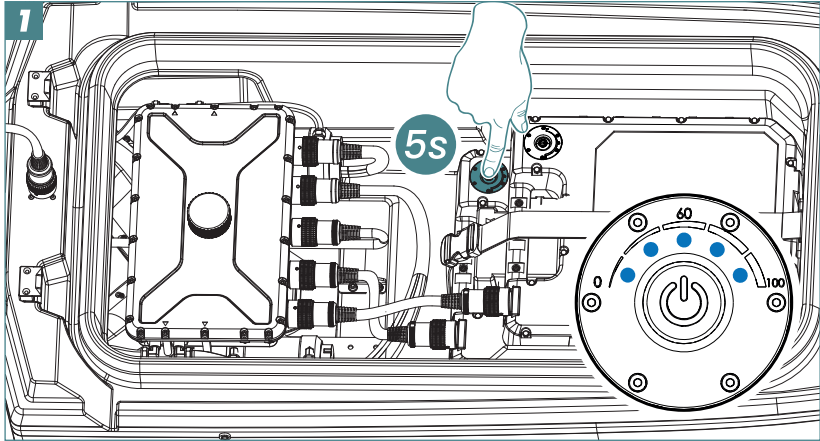

7. AFTER USE

Maintain your eTow after each use:

The eTow needs to be checked regularly and maintained to ensure good working order and to reduce the risks of degradation.

Always flush the pump holes to clear of any sand, rocks, debris that can damage the components.

Never allow sand and/or seawater to get in the connectors or it may cause significant damage.

Always make sure the connectors are clean and dry and apply a thin layer of connector grease regularly.

Check your eTow thoroughly after each use to make sure everything is OK (screws, cover, etc.)

Only pack your eTow away after it is completely dry. Before storage, always check that it is completely dry.

If needed, contact your TAKUMA authorized dealer for assistance.



After each use, rinse your eTow: Rinse the outside and inside with fresh water without disconnecting the cables.

Dry the inside of the with a clean dry cloth until there is no sign of water left.

Also dry the ESC, battery and connector caps.

If the connectors get wet, rinse them with clean fresh water, then use a canister of compressed air to blow out the water. Once its completely dry, apply a thin layer of connector grease such as dielectric grease or NyoGel®.

Once the connector caps are dry, screw them directly back onto the connectors.

Remove the battery. Dry it completely and store it in a dry place.

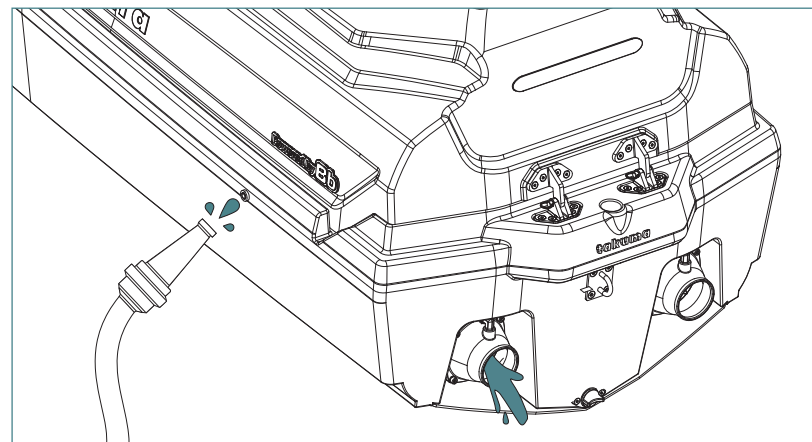

Flush water spouts on each side of hull after ever use.



Open the hull drain plug when you rinse the inside with freash water.

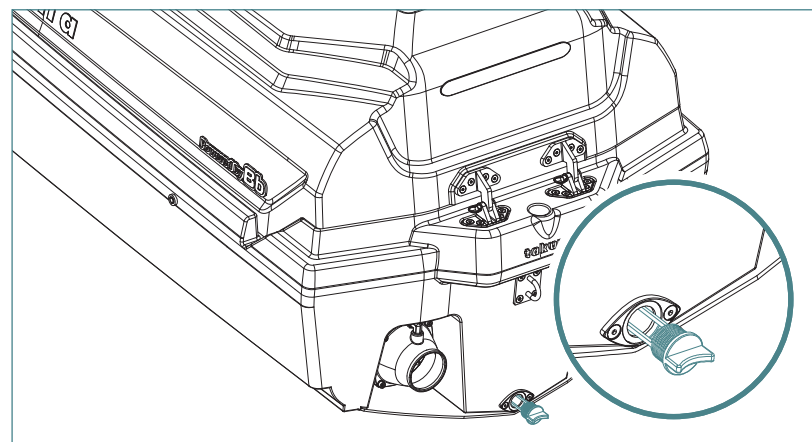

8. MAINTENANCE & WARRANTY

EN

Battery storage

Do not place the battery directly on sand or immerse in water. Keep the battery and remote control out of direct sunlight.

Once the battery is charged, disconnect. Do not store the battery on continuous charge.

For optimum battery lifespan, we recommend you charge the battery every 3 months to 80% if storing for a long period of time.

Best temperature for battery storage is between 10-25°C.

Takuma eTow require regular servicing just like any other powered watercraft. To ensure top working condition and to prevent malfunction, your eTow requires regular Preventative Maintenance along with the initial service every 6 months/40 hours of use (whichever comes first).

For the Maintenance details and Takuma service locations, please visit our [Website](http://www.takuma.com) (www.takuma.com).



Please refer to our website to review the full terms and conditions of sale



Latest version of this User Guide



takuma

Please find our tutorial videos on our youtube channel:
<http://youtube.takuma.com>

