

# ***e-foil jet***

**EN**

USER'S GUIDE



**takuma**

*fly above water*



# Contents

<b>1.</b>	<b>GENERAL</b>	2
1.1	About	2
1.2	Safety	3
1.3	Battery and components disposal	10
<b>2.</b>	<b>PACKAGE CONTENTS</b>	11
<b>3.</b>	<b>PREPARATION</b>	13
3.1	Battery charging	13
3.2	Remote charging	15
<b>4.</b>	<b>ASSEMBLY</b>	16
4.1	Jet ESC installation	16
4.2	Jet ESC antenna installation	17
4.2	Foil and Jet propulsion assembly	18
4.3	Jet propulsion to Jet ESC connection	23
4.4	Battery installation	24
<b>5.</b>	<b>USE</b>	26
5.1	Activation and pairing	26
5.2	Pairing failure	28
5.3	How to use remote	30
5.4	Safety cut off	33
5.5	Low battery warning	34
5.6	Power off	35
<b>6.</b>	<b>MAINTENANCE &amp; AFTER USE</b>	36
<b>7.</b>	<b>WARRANTY</b>	37

# 1. GENERAL

## 1.1 About



**Read the guide carefully.**

Please carefully read the instructions and the safety warnings presented in this guide before assembling and using the product. Keep the guide in a safe place in order to refer to it later.

Copyright © 2021 by TAKUMA.

The information presented in this guide is the property of TAKUMA. It cannot be reproduced, partially or in full, without prior authorization from us.

The illustrations are provided to facilitate comprehension. They have no contractual nature.

The information in this manual was accurate at the date of publication. However, specifications can be modified at any time without notice.

For up-to-date product information, please visit [www.takuma.com](http://www.takuma.com)

### Symbols used



**Information:**

Indicates pertinent information making it easier to use the product.



**Warning:**

Indicates a potential risk that can cause slight injury or material damage if the instructions are not complied with.



**Danger:**

Indicates immediate danger that can cause serious and even fatal injuries and serious damage, if the instructions are not complied with.

## 1.2 Safety



*To use the TAKUMA E-FOIL JET safely and responsibly, the following instructions must be read and complied with.*

*TAKUMA cannot be held liable for non-compliance with the warnings and instructions in this guide.*

### 1.2.1 Navigation



**The following is strictly prohibited:**

*It is strictly prohibited to tow a person with the TAKUMA E-FOIL JET in any way whatsoever. Doing so would result in serious and even fatal injuries. TAKUMA cannot be held liable in the event this warning is not complied with.*

The TAKUMA E-FOIL JET is subject to local laws and regulations in terms of navigation. It may be necessary to obtain a license or a permit to use TAKUMA E-FOIL JET in certain areas or countries. Always observe local rules and regulations when using this product.

Never navigate alone.

Give priority to the right (starboard) at sea, on lakes and rivers.

At sea, when leaving the coast, move at a slow speed (less than 5 knots or 9 km/h), without flying, until you leave the coastal strip of 300 metres.

In ports, comply with the maximum speed (5 knots except for other local regulations). Do not fly.

In rivers and lakes, obtain information on the authorized navigation zones and speeds.

Observe the body of water where you will be moving about before getting into the water.

Make sure there is no dominant wind that will push you out to sea.

Be able to keep track of where you are at any time in your navigation zone. Where did I leave from, are there any swimmers and where are they? Are there any other watercraft, where are they, how fast are they moving?

The TAKUMA E-FOIL JET must never be used near other people (swimmers, surfers, divers, etc.). Also always maintain a safe distance of 100m with respect to other watercraft or any other obstacle.

Do not navigate in waves, as your view of swimmers and/or surfers will be obstructed.

Do not use TAKUMA E-FOIL JET in shallow water (less than 2 m deep), near rocky areas or in the presence of algae, or in the open sea.

Never use TAKUMA E-FOIL JET in sea or weather conditions that are above your level of physical ability.

Do not use the TAKUMA E-FOIL JET in a thunderstorm or severe weather conditions.

The TAKUMA E-FOIL JET is not a piece of equipment for surfing, it is not suitable for riding breaking waves. Doing so can cause significant and personal damage. Riders do so at their own risk.

Never leave your TAKUMA E-FOIL JET near shore break waves. Doing so may cause serious damage. Avoid all contact between the E-FOIL JET and rocks, coral, sticks or other types of debris.

Do not jump on the TAKUMA E-FOIL JET from other watercraft or boats or vice versa.

In the event of a problem during navigation (operation ceases), lie flat on your stomach on your E-FOIL JET and paddle in the direction of the coast or the nearest shelter.

## 1.2.2 Users

---



**Using TAKUMA E-FOIL JET can be dangerous:**

*This product must be operated with caution and common sense. It requires some foiling ability.*

*When using this product, you are responsible for your safety as well as the risks. Always take the safety of your environment into consideration.*



**Risk of personal injury:**

*The TAKUMA E-FOIL JET mast has sharp edges. Please be very cautious when preparing and operating. Avoid any impact as these sharp edges can cause serious and even fatal injuries.*

The TAKUMA E-FOIL JET is an individual product and should only be used by one adult at a time.

The TAKUMA E-FOIL JET is not to be used by children under 18 years of age.

Make sure you are able to use this product in a safe and responsible manner before you start using it. Do not use it if you are not in good physical health, if you are not an experienced swimmer, or if you are under the influence of alcohol, drugs or medications.

Maintain a safe distance from others and away from any obstacles. Check for any legal requirements and rules that may apply in your location. Observe local weather forecasts and never go out in dangerous conditions.

The following are required when using your E-FOIL JET:

- **a certified personal flotation device (PFD)**
- **a certified helmet**
- **a full neoprene wetsuit, booties and gloves**
- **a lighted positioning device (a waterproof torch as part of the PFD or worn by the user)**
- **a VHF radio or a waterproof mobile telephone**

By using this product, you agree that you do so at your own risk. TAKUMA does not accept any responsibility for personal injury or material damage in the case of an accident due to incorrect use.

### 1.2.3 E-FOIL JET

---

Do not leave your TAKUMA E-FOIL JET in direct sunlight or moving in the wind for long periods of time when not in use.

Do not leave your TAKUMA E-FOIL JET on hot surfaces such as asphalt or sand for long periods of time.

Never leave your TAKUMA E-FOIL JET in an overheated place, such as in a hot car. Doing so may cause serious damage.

Do not operate your TAKUMA E-FOIL JET when it is not in the water. Doing so will cause it to overheat and may permanently damage the motor.

### 1.2.4 Jet impeller

---



***Risk of personal injury:***

*The TAKUMA E-FOIL JET impeller carries risks of serious and even fatal injuries.*

*Keep body, fingers and toes away from the TAKUMA E-FOIL JET's spinning impeller.*

*Never start the Jet impeller when out of the water.*

Never remove the casing of the jet impeller.

Never touch or handle the jet impeller while the battery is connected. If intervention is required on the jet impeller (to remove a foreign body, for example), the battery must be removed first.



## 1.2.5 Electrical parts, batteries and chargers



*Before handling the electrical connections of the TAKUMA E-FOIL JET, the battery or the chargers, make sure you are in a dry place away from water splashes. Never operate in the water or in the presence of humidity.*

*Never open the electrical connectors when your E-FOIL JET is on the water.*

*Never change your battery when your E-FOIL JET is on the water.*

*Do not attempt to open or modify the electrical parts, battery or charger.*



*Do not use or charge a damaged battery, if it was involved in any kind of heavy impact or crash. Doing so can cause the battery to catch fire.*

*Please contact your local TAKUMA dealer for further assistance.*

**Signs of a damaged battery:**

*Loose screws/rivets/connectors*

*Split or deformed case*

*Acidic smell*

*Unusually hot temperature during charging (80°C or more)*

Do not disassemble the battery in any way. Water may penetrate causing battery to catch fire or explode.

Do not use other batteries or chargers than those sold by TAKUMA. Any damage caused by the use of another battery or charger will not be covered by warranty.

Place the battery and the charger in a clean and dry place, out of the reach of children under 18 years old.

Keep the battery away from fire, heating sources and out of direct sunlight.

The battery must be used in the temperature range from 0°C to 40°C. Do not use or charge the battery at high temperature. Use of the battery in environments above 40°C can lead to a fire or an explosion.

Use of the battery below 0°C can lead to permanent damage to the battery.

Avoid any form of impact or physical damage.

Always inspect before every use.

Do not use if there's visible damage or cracks on the housing, loose screws, acidic smell. Doing so can lead to fire.

Do not let the connectors come in contact with water or wet hands.

Make sure there is no corrosion in the battery before connecting to your E-FOIL JET or charger.

After use, make sure battery cap is completely dry before screwing back on.

Only use the charger supplied to charge the battery.

The battery charger must be used in a standard voltage outlet (110V or 220/230V).

Always charge your battery in a dry place.

If the battery has been exposed to water, place it in a cool dry place until it is totally dry.

If a charger is wet, stop using it immediately.

Never leave unattended while charging.

Do not leave the charger plugged in when not used.

If the battery is not to be used for a long time, then it needs to be charged every 3 month to 80% in order to preserve its lifespan.

## 1.2.6 Electronic Speed Control (Jet ESC)

---



*The Jet ESC is mounted inside the TAKUMA E-FOIL JET.*

*It allows you to vary the jet's speed via the remote control.*

*It is controlled by the remote control.*

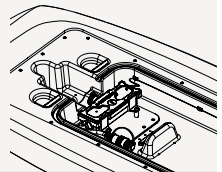

**Connectors:**

*Never allow sand and/or water to get in the connectors of the Jet ESC or battery, or it may cause significant damage.*



*Only use the Jet ESC for the Jet propulsion. Using the regular non Jet ESC from Takuma will cause irreversible damage to the Jet propulsion.*

Do not use other ESC than the Jet ESC sold by TAKUMA. Any damage caused by the use of another ESC will not be covered by warranty.

If the product is not to be used for an extended period, the Jet ESC must be stored so as to remain clean and dry.

Keep the Jet ESC away from sources of heat and out of direct sunlight. Avoid any high temperatures.

Do not leave or use the Jet ESC near fire.

Do not alter or disassemble the Jet ESC.

Prevent any impact with the Jet ESC and do not drop it.

If your Jet ESC is damaged, contact your TAKUMA authorized dealer for further assistance.

### *1.2.7 Remote control*

---

Do not open the remote control case.

Do not modify or disassemble the device. If the device becomes damaged, stop using it immediately.

Do not expose this device to extreme temperature.

Never use the device near medical devices and/or near a person with an electronic medical device (such as pacemaker, etc.).

Do not use the device in an airplane.

### 1.3 *Battery and components disposal*

When it is suspected that the device is no longer safe, for example after damage incurred during transport or use, the defective device must be taken out of service. It is necessary to ensure that it will not be used later. Please contact your local TAKUMA dealer for more information.

The defective product will be entrusted to authorized technicians for the purposes of control.



*This marking indicates, in the European Union, electric and electronic devices that must be separated from household waste.*

*In order to preserve the environment, this device must be disposed of in compliance with the appropriate sectors according to the national regulations of each Member State.*

# 2. PACKAGE CONTENTS

EN

## Box 1:

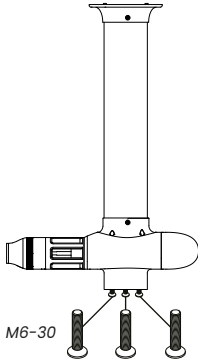

M6-30  
Jet Propulsion Mast

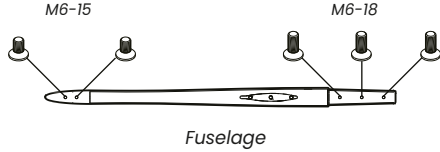

M6-15 M6-18  
Fuselage

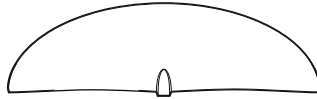

Front wing & cover

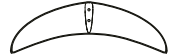

Back wing & cover

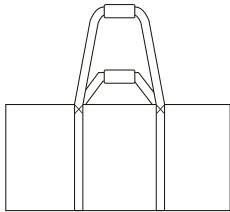

Travel case



Jet ESC

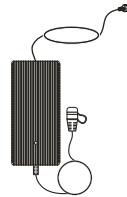

Battery charger



Remote control  
charger & USB cable



Remote control

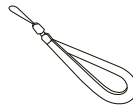

Wrist strap



Torx key

### Screw box:



(Extra screws and  
T-Nuts)



Connector grease



Cable clips

**Box 2:**

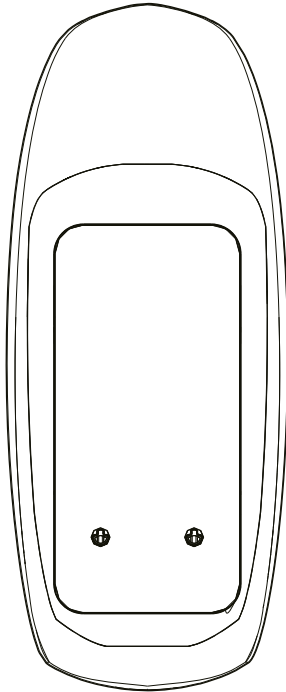

Board

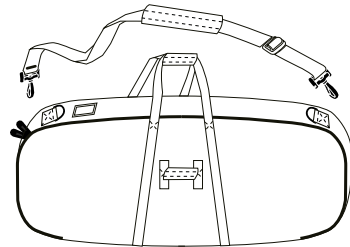
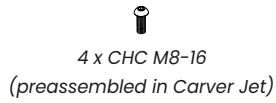
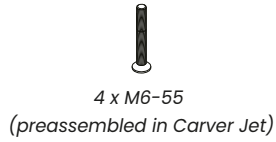

Board bag

**Box 3:**

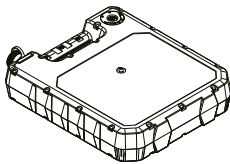

Battery

# 3. PREPARATION

## 3.1 Battery charging



**Before using for the first time, charge the battery 100%.**

Charge the battery at least once within 3 months after delivery. The battery will reach its full capacity after 3 or 4 charging/discharging cycles.



Check that the device and the battery connector are completely dry. Ensure that you are in a dry place away from splashes of water. Never operate in the water or in the presence of humidity.

Do not charge immediately after use. Charging a hot or cold battery can damage cells. Wait 30mins to 1hr to let the battery cool down or warm up to room temperature.

Best temperature for charging is between 15-25°C.

Do not drop battery.

Charging a damaged battery can cause the battery to catch fire.

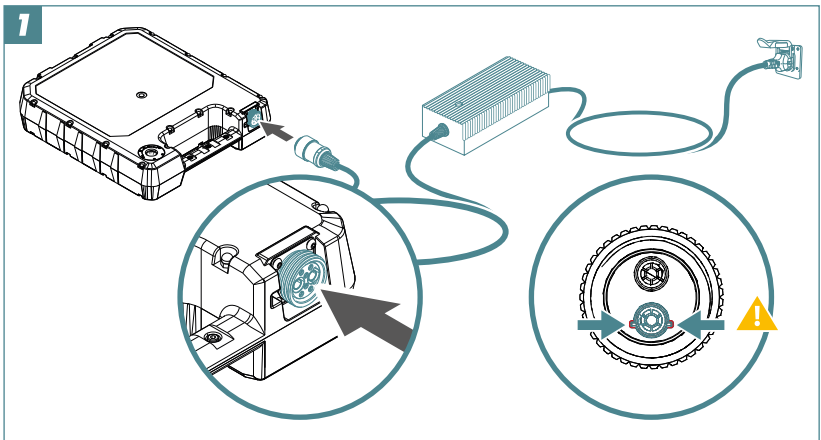

The pins will only connect if the notches are properly aligned. No great force is needed.

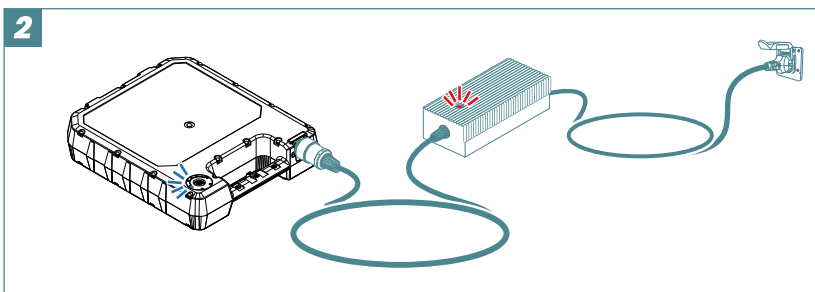

Once the battery is connected to the charger, the light on the charger should turn red.

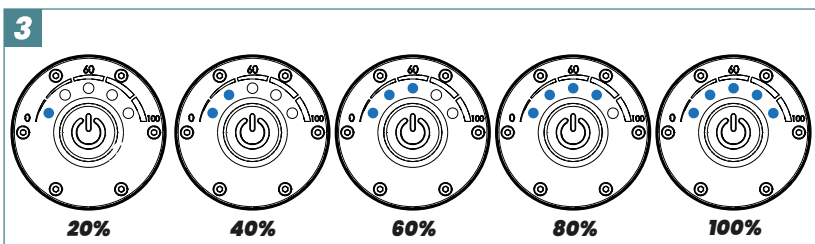

The blue battery LEDs allow you to monitor the progression of the charge.

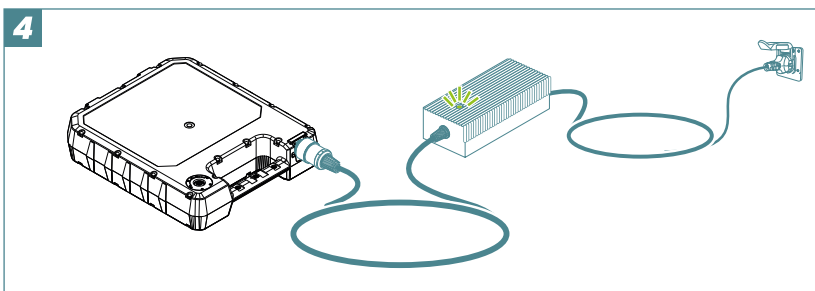

Once the battery is fully charged, all the LEDs go out and the charger indicator turns to green.

Disconnect the charger from the wall socket.

Disconnect the battery from the charger. Place the protections back on the connectors in order to ensure watertightness.



## 3.2 Remote charging



**Before using for the first time, charge the remote control 100%.**  
Charge the remote control at least once within 3 months after delivery.



*The remote control must be completely dry before charging.*

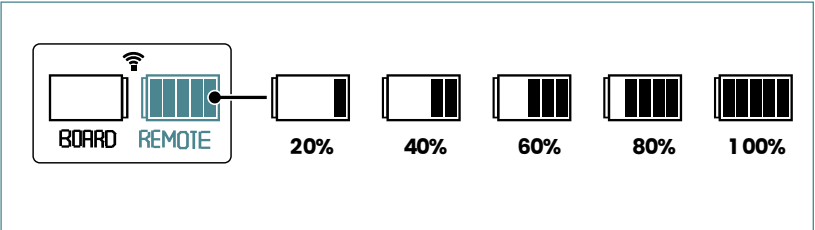
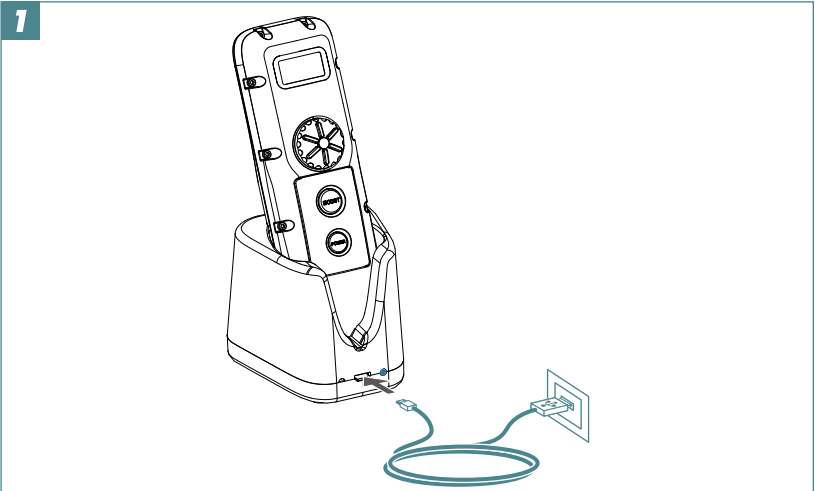

# 4. ASSEMBLY



To facilitate the assembly of the TAKUMA E-FOIL JET, we recommend watching the tutorials on our channel <http://youtube.takuma.com>



Assemble your TAKUMA E-FOIL JET in a clean and dry place.



Only use the Jet ESC for the Jet propulsion. Using the regular non Jet ESC will cause irreversible damage to the Jet propulsion.

Apply anti-corrosion gel on all screws to avoid corrosion.

## 4.1 Jet ESC installation

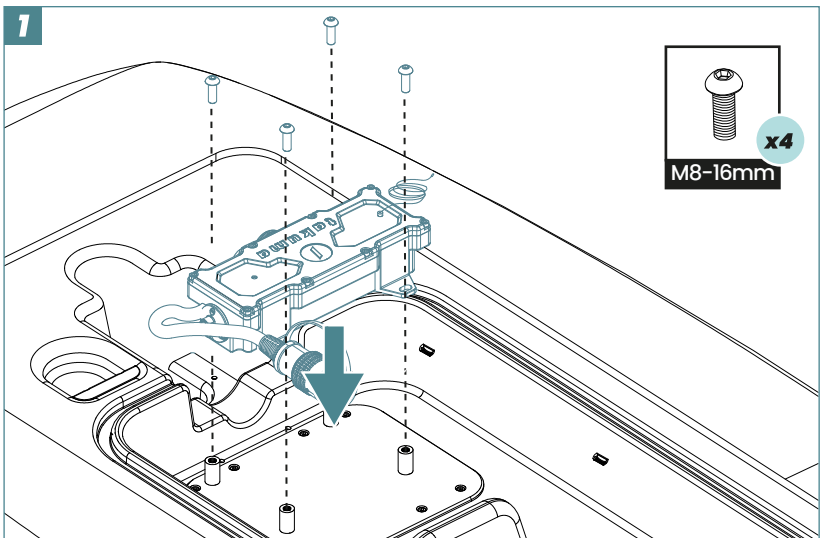

## 4.2 Jet ESC antenna installation

### Efoil Cruising Jet



Clean area with alcohol and allow to dry before attaching clips. Press antenna cable firmly onto the clips. Place antenna near the top without obstructing the lid from closing.

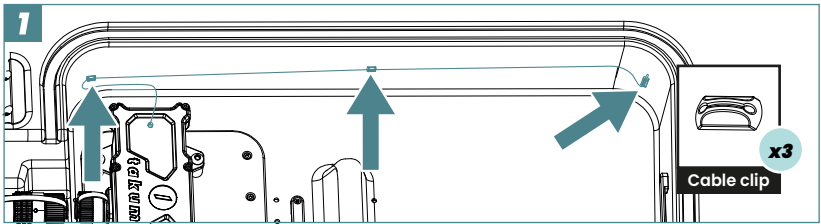

### Efoil Carver Jet



Press antenna cable firmly onto the clips. When attaching EVA strip be sure to clean the area with alcohol and allow to dry first. Wait at least 12 hours before going in the water.

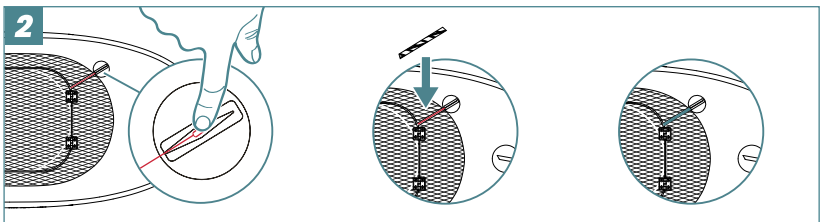
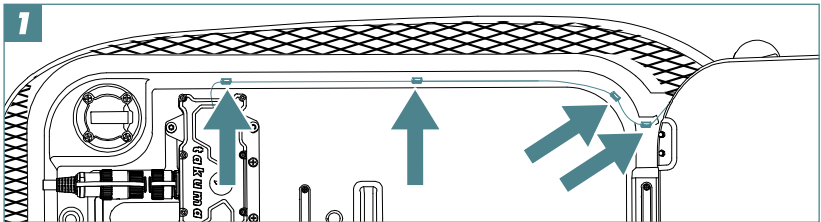

## 4.3 Foil and Jet propulsion assembly



Always check and tighten every screw before each session.  
Vibrations from the motor and foiling may loosen the screws.

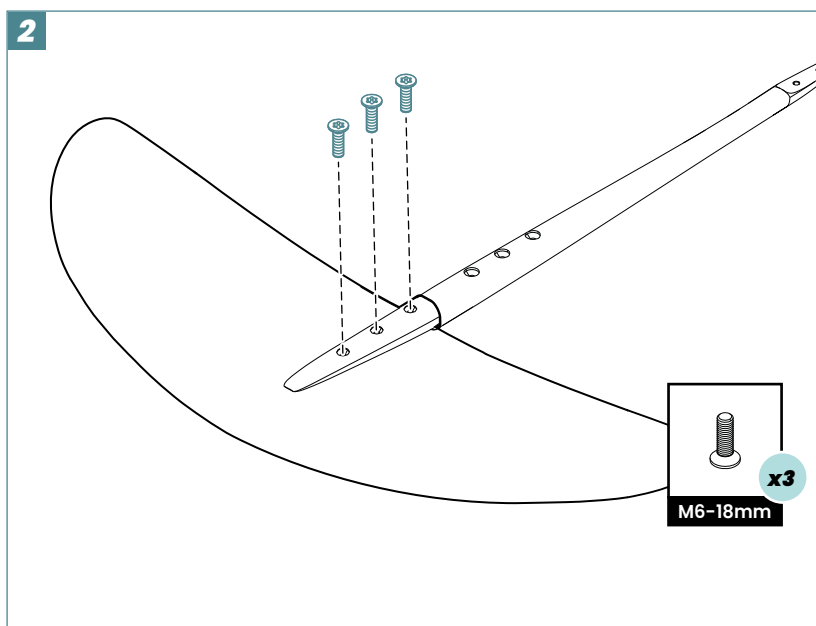
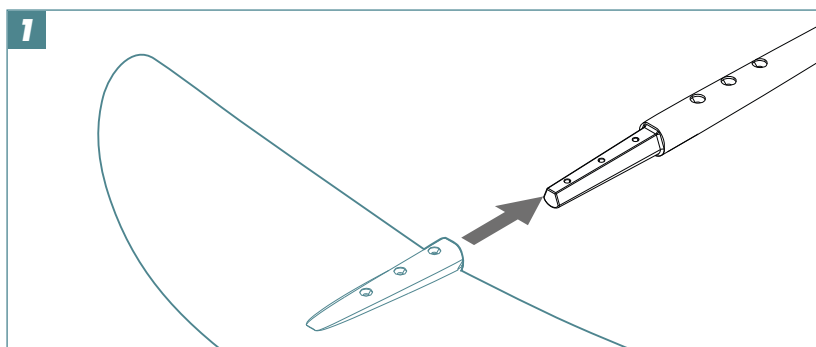

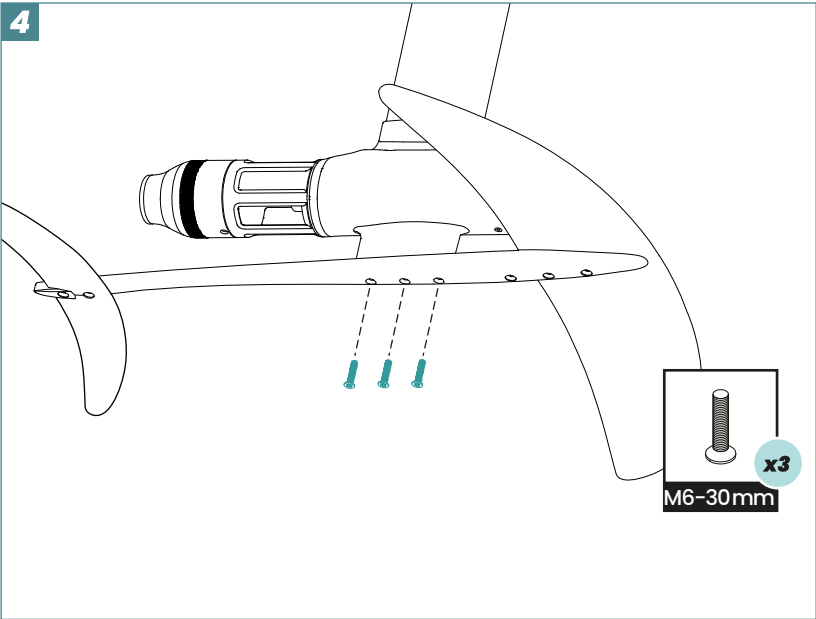
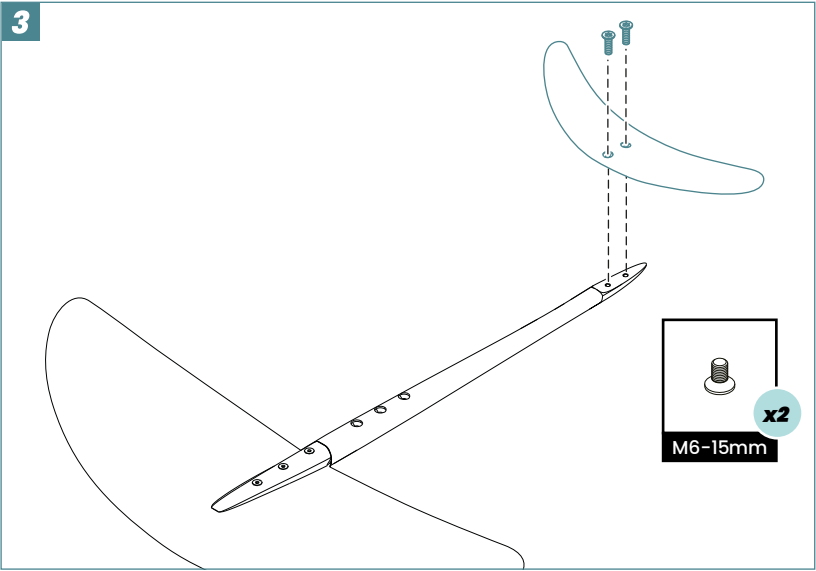

## Efoil Carver Jet

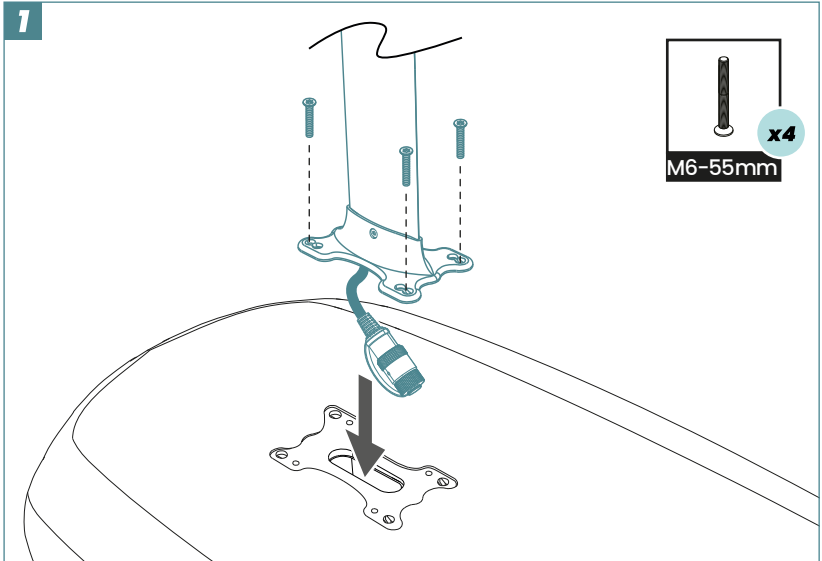

## Efoil Cruising Jet

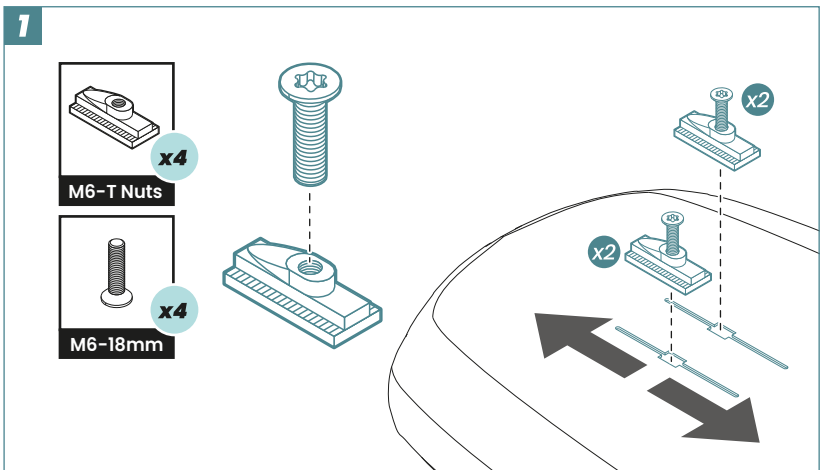

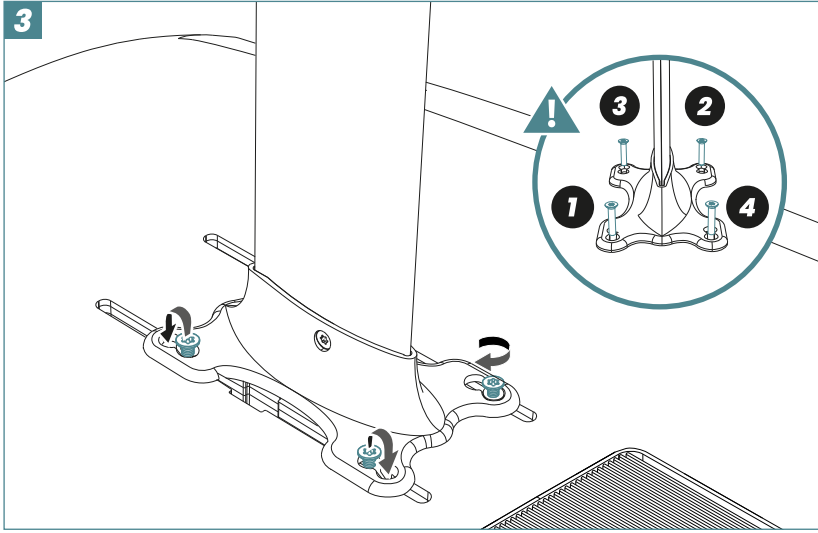
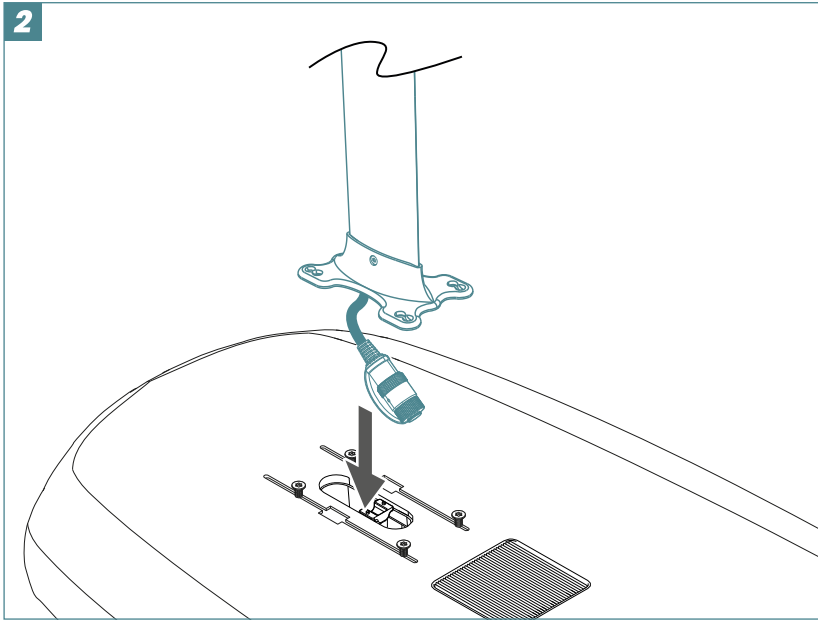

## Foil Position (Cruising Jet)

For more lift

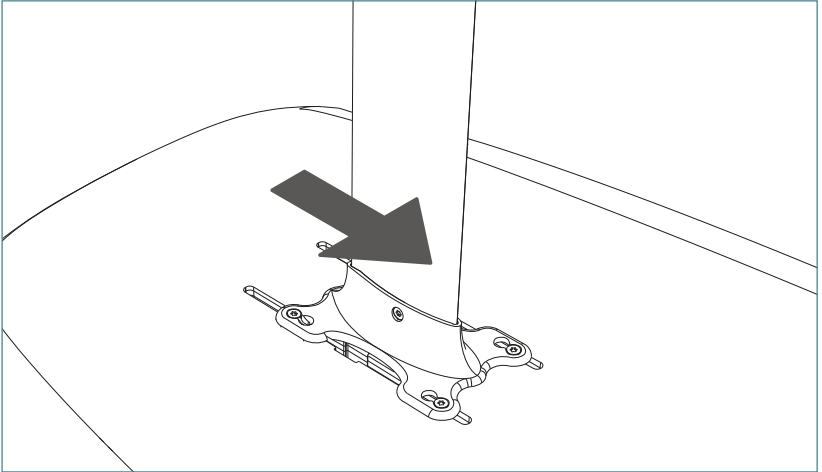

For less lift

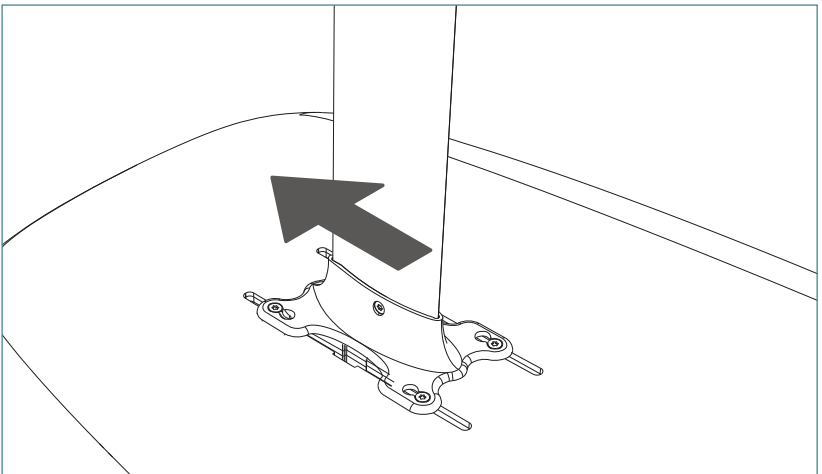



## 4.5 Jet propulsion to Jet ESC connection

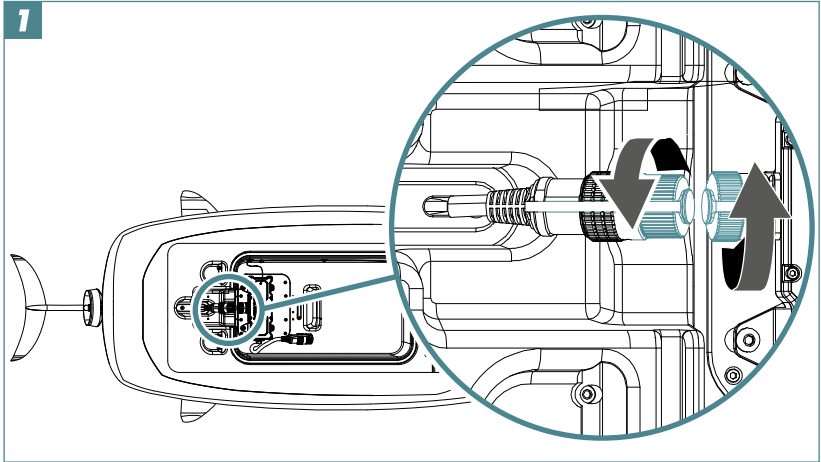

**After removing the 2 caps:**

Screw together the 2 M/F caps of the connectors.

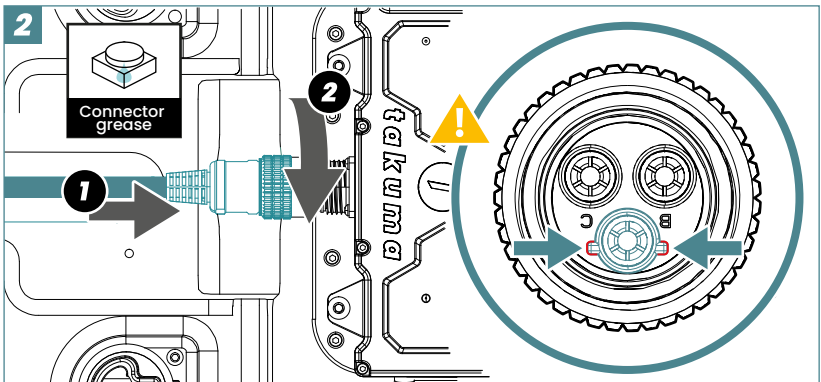
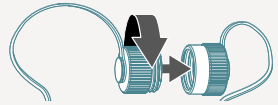

*The pins will only connect if the notches are properly aligned.  
No great force is needed.*

## 4.6 Battery installation

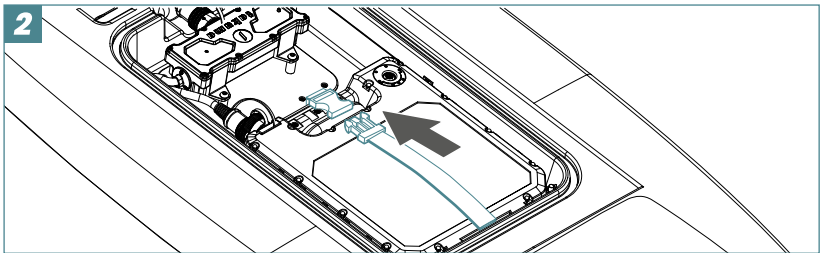
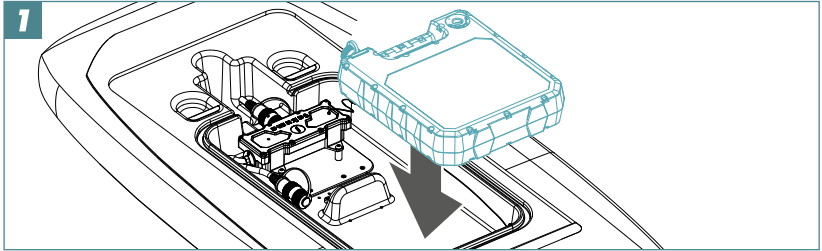

*Make sure to position the buckle near the battery handle in order for the lid to close properly.*

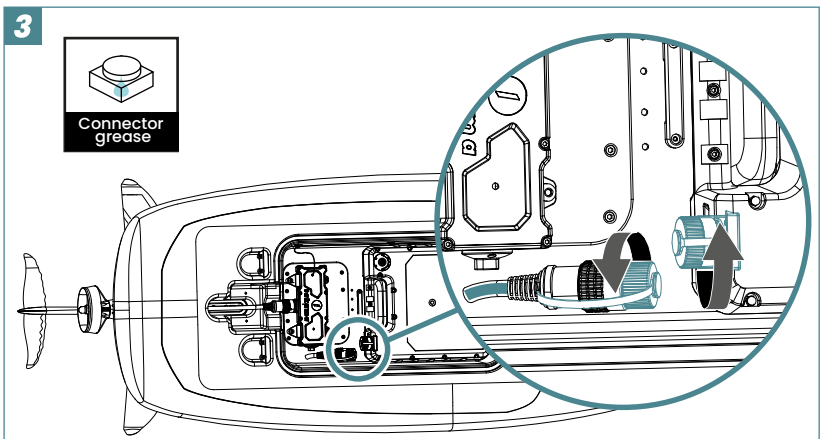

**After removing the 2 caps:**

Screw together the 2 M/F caps of the connectors.

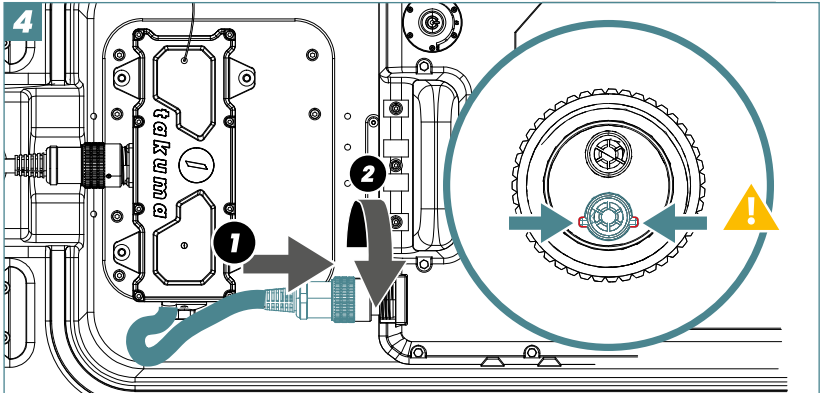
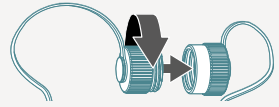

*The pins will only connect if the notches are properly aligned.  
No great force is needed.*

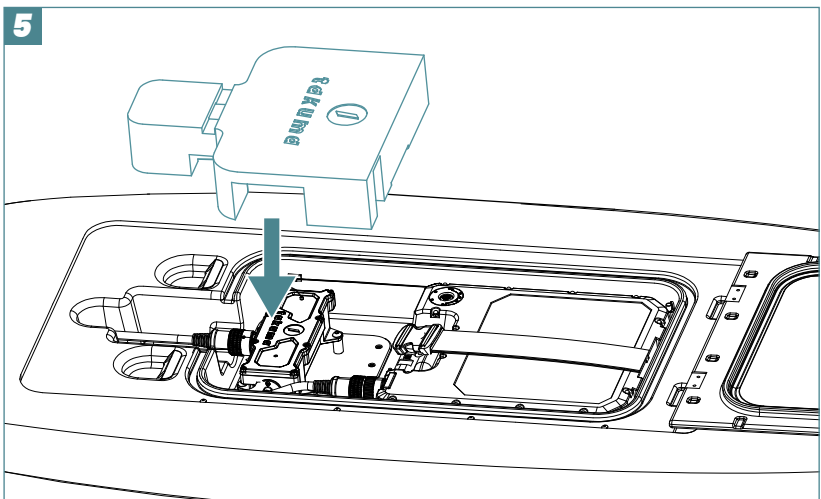

# 5. USE

## 5.1 Activation and pairing

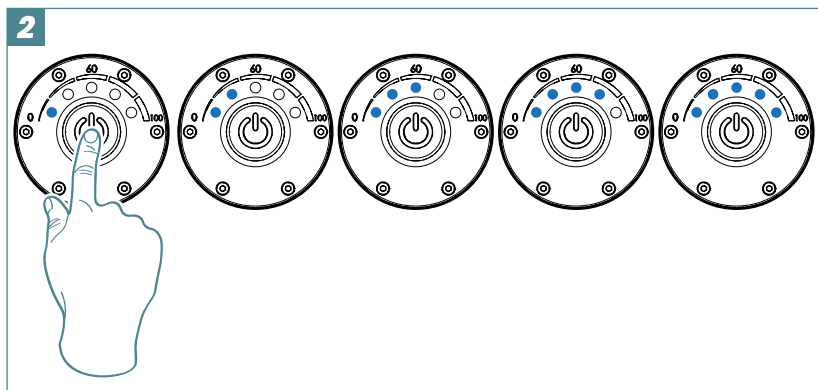
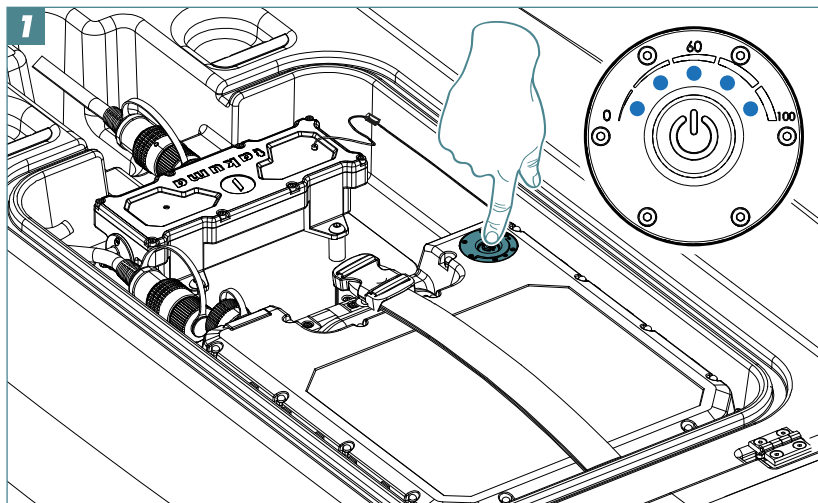

Keep you finger on the button until all 5 led lights are on.

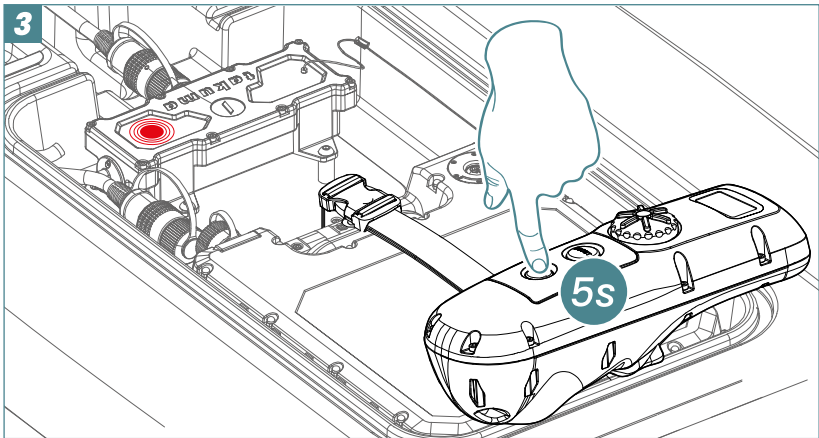

Hold down on the power button even after the remote has turned on until it is paired.

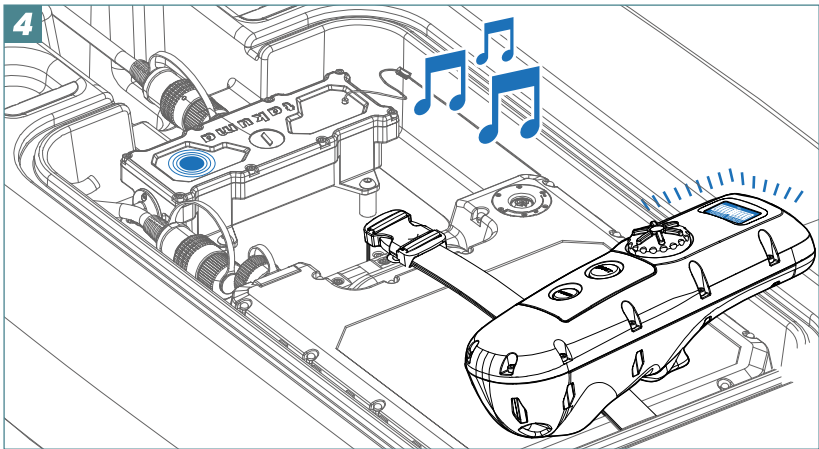

## 5.2 Pairing failure

If the Jet ESC light remains red, this means that the remote control cannot connect to the board.



The barred wifi is shown in the middle of the screen.

Make sure that connectors are clean and completely dry with a thin layer of connector grease.

Try to pair again, turn off the remote and battery and repeat the activation and pairing steps.

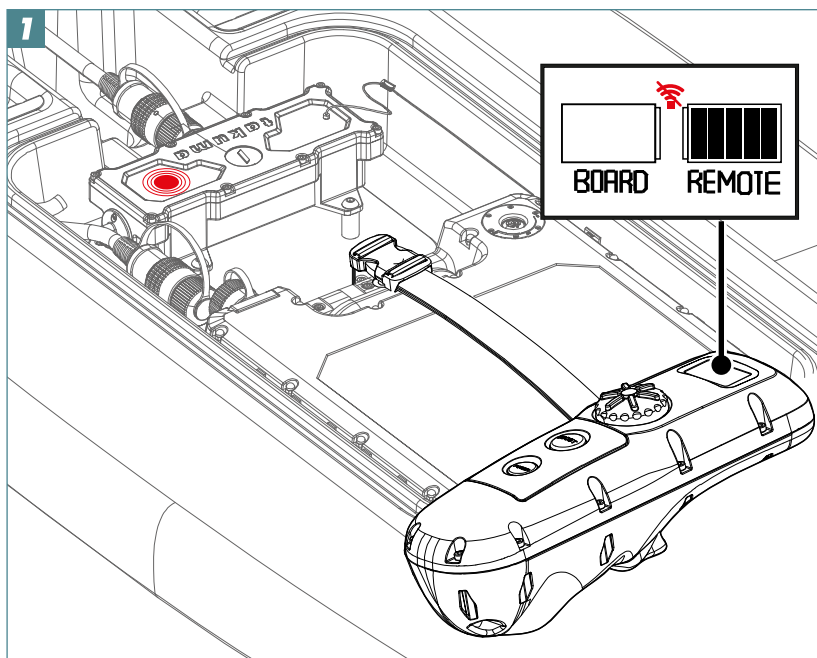

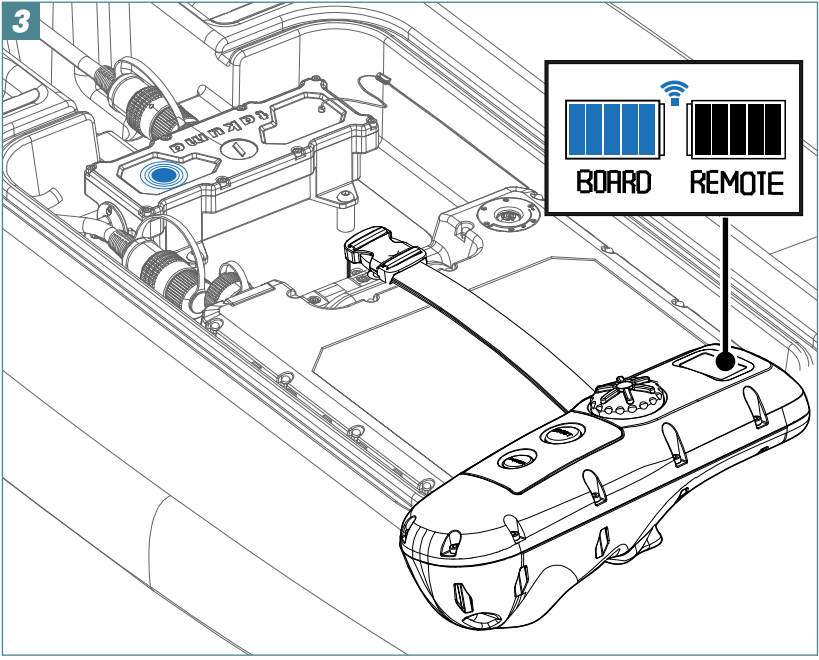
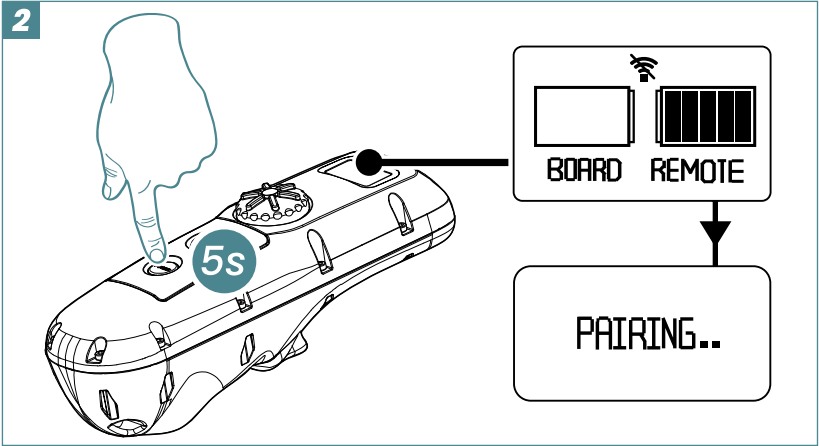

## 5.3 How to use remote



To facilitate learning how to use the TAKUMA E-FOIL JET, we recommend watching the tutorials on our channel <http://youtube.takuma.com>

We also recommend to start practicing with an instructor.

### 5.3.1 Remote control

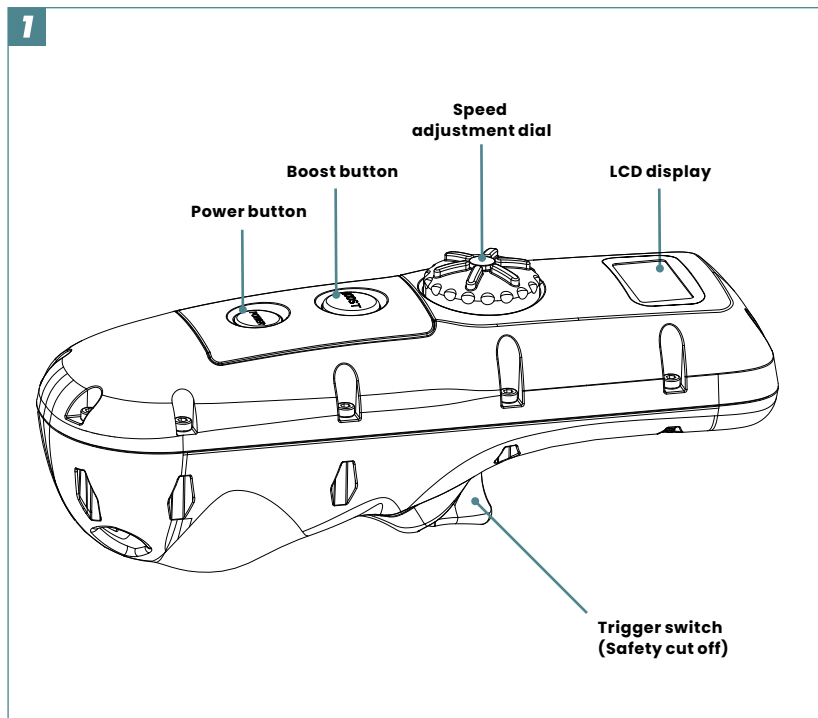



### 5.3.2 Trigger switch and speed adjustment dial

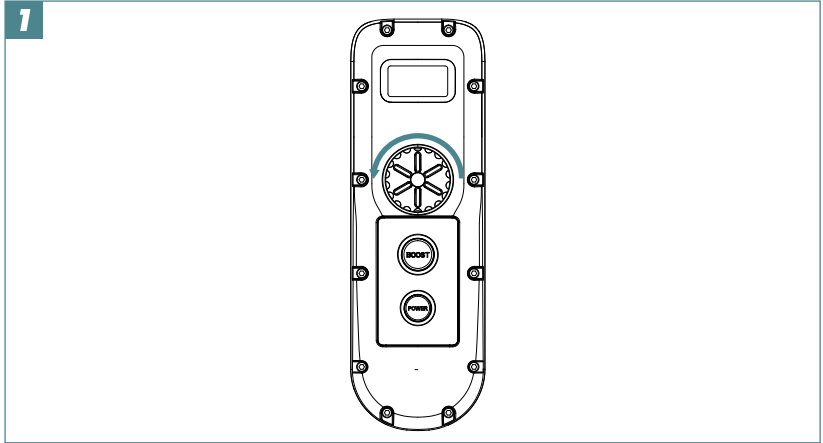

The speed adjustment dial must be at the minimum setting before you can start the Jet propulsion.

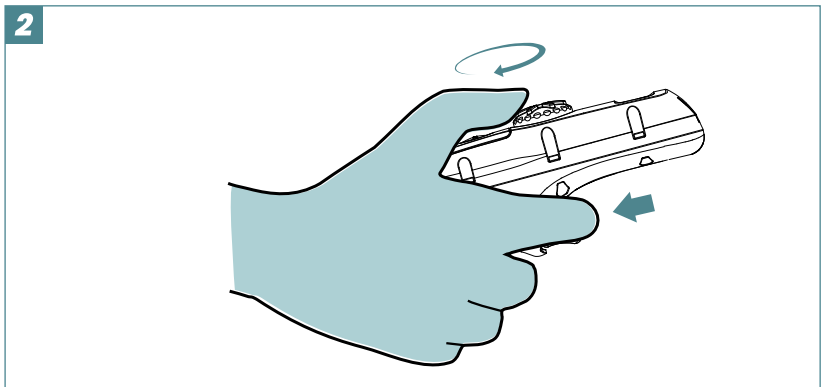

Press down on the trigger and turn speed adjustment dial to start the Jet propulsion.

The trigger must be pressed continuously during the entire use.

Turn the speed adjustment dial to adjust speed.

Once the trigger is released the jet propulsion stops.

3

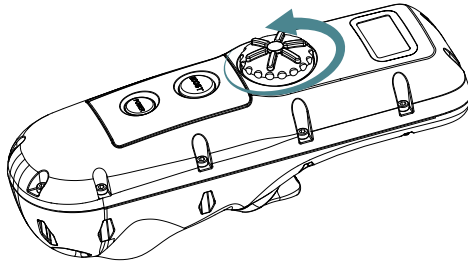

When you release the trigger, the speed adjustment dial must always be set back to the minimum setting before you can start the Jet propulsion again.

### 5.3.3 Boost mode

1

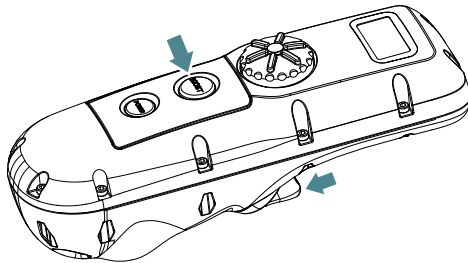

Pressing the boost button increases the speed by 20%.

Releasing the button will return you to the initial speed.



*Boost mode will allow beginners to have a much smoother take off. You can then take off more easily, without having to adjust the speed.*

## 5.4 Safety cut off

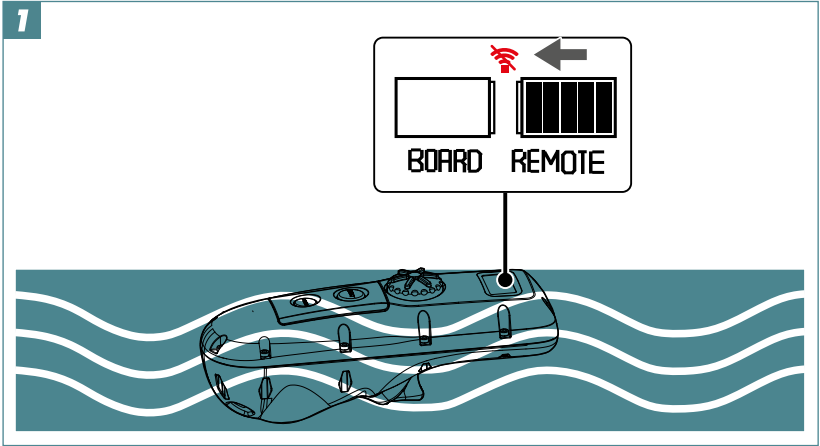

If the remote hits the water the connection and the motor will cut off.

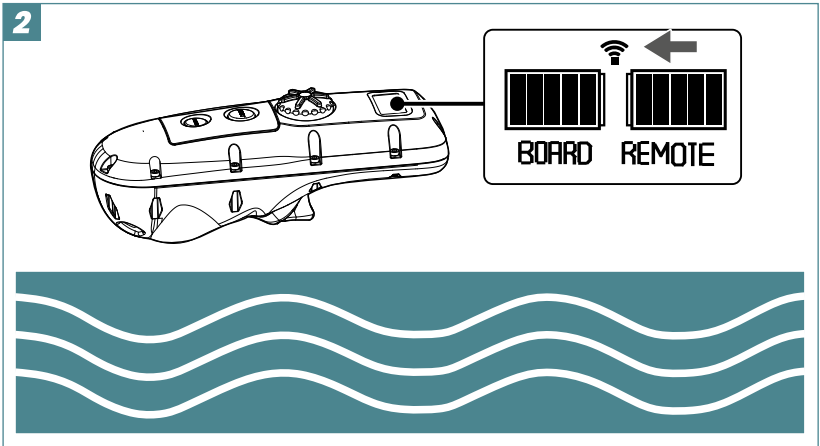

The signal automatically comes back on when the remote control is outside the water.

3

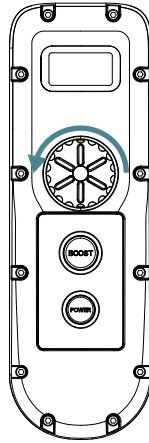

The speed adjustment dial must be put back to the minimum setting before starting the Jet propulsion again.

## 5.5 Low battery warning

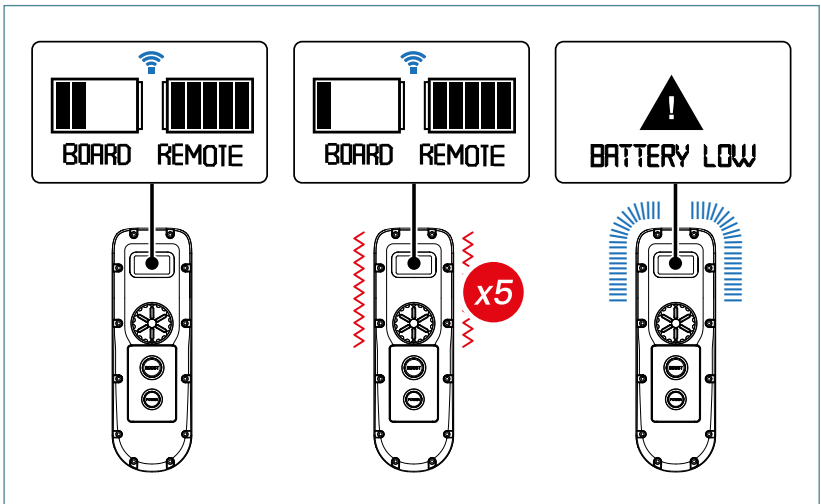

## 5.6 Power off

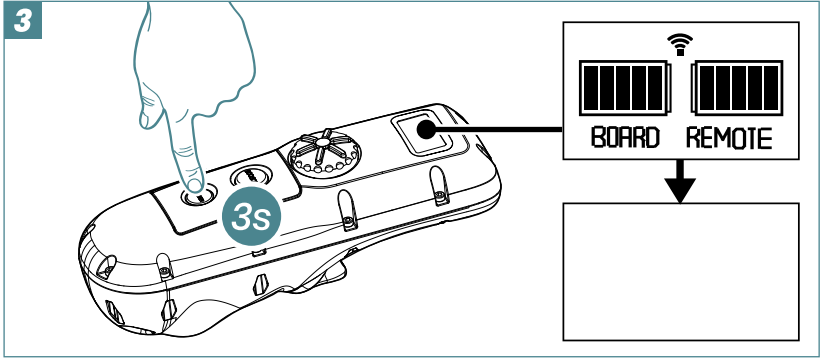
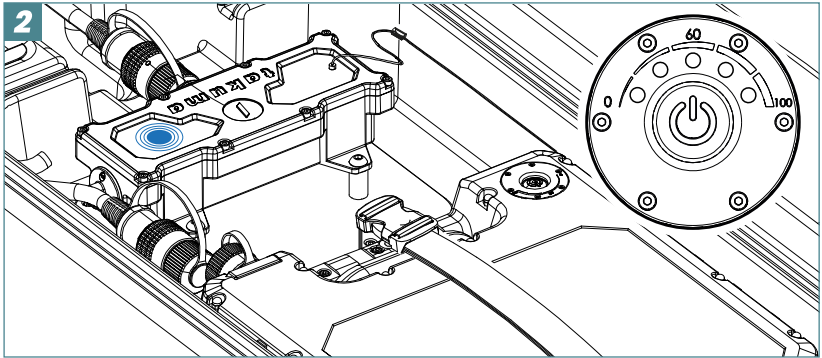
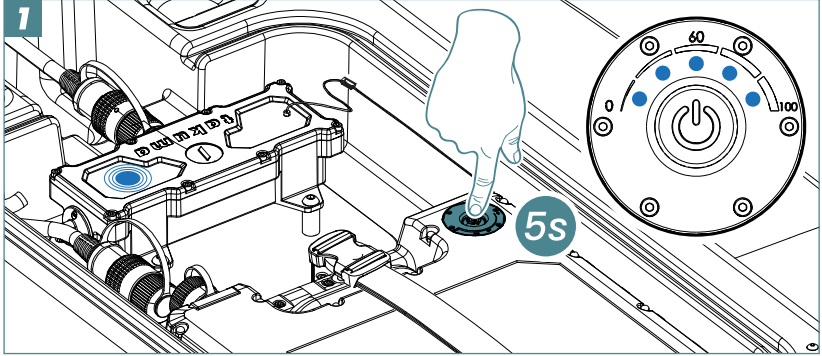

## 6. AFTER USE

### **Maintain your E-FOIL JET after each use:**

*The TAKUMA E-FOIL JET needs to be checked regularly and maintained to ensure good working order and to reduce the risks of degradation.*

*Never allow sand and/or seawater to get in the connectors or it may cause significant damage.*

*Always make sure the connectors are clean and dry and apply connector grease regularly.*

*Check your E-FOIL JET thoroughly after each use to make sure everything is OK (screws, cover etc.)*

*Only pack your E-FOIL JET away after it is completely dry. Before storage, always check that it is completely dry.*

*Apply TEF GEL on the screws regularly.*

*If needed, contact your TAKUMA authorized dealer for assistance.*



After each use, rinse your E-FOIL JET: Open the top cover of the board and rinse with fresh water without disconnecting the cables.

Also rinse the Jet propulsion mast and the impeller.

Dry the inside of the board with a clean dry cloth until there is no sign of water left.

Also dry the Jet ESC, battery and connector caps.

If the connectors get wet, rinse them with clean fresh water, then use a canister of compressed air to blow out the water. Once its completely dry, apply a thin layer of connector grease such as dielectric grease or NyoGel®. Once the connector caps are dry, screw them directly back onto the connectors.

Remove the battery. Dry it completely and store it in a dry place.

### **Battery storage**

Do not place the battery directly on sand or immerse in water. Keep the battery and remote control out of direct sunlight.

Once the battery is charged, disconnect. Do not store the battery on continuous charge.

For optimum battery lifespan, we recommend you charge the battery every 3 months to 80% if storing for a long period of time.

Best temperature for battery storage is between 10–25°C.

# 7. MAINTENANCE & WARRANTY

Takuma e-foils require regular servicing just like any other powered watercraft. To ensure top working condition and to prevent malfunction, your efoil requires regular Preventative Maintenance along with the initial service after 6 months/40 hours of use (whichever comes first) from the time of purchase. It will then require an additional interval service every 12 months/80 hours of use (whichever comes first).

For the Maintenance details and Takuma service locations, please visit our [Website](http://www.takuma.com) (www.takuma.com) or contact [After-Sales Service](mailto:customerservices@takuma.com) (customerservices@takuma.com).



Please refer to our website  
to review the full terms and conditions of sale



Latest version of this User Guide



**takuma**

*fly above water*

**After-Sales Service:**  
[customerservices@takuma.com](mailto:customerservices@takuma.com)

**Please find our tutorial videos on our youtube channel:**  
<http://youtube.takuma.com>

